

Vacuum Module

Series ZX

Ejector System/Vacuum Pump System



■ For electronic components and precision components up to 100 g

■ Modular design
Customized application function through selection of module components.

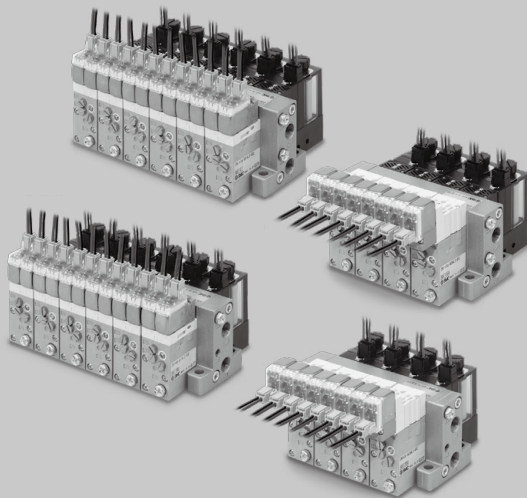

INDEX

Characteristics/Application Examples	P.864
Modular Components Introduction	P.865

Ejector System

How to Order	P.866
Combination of supply valve and release valve	P.868
Construction	P.869
Ejector unit	P.870
Valve unit	P.872
Suction filter unit	P.874
Vacuum pressure switch unit	P.875
Dimensions/Without valve unit	P.881
Dimensions/Combination of supply valve and release valve Type K1, K3, K8, J1, J2	P.882 to 893
Manifold specifications	P.894
Dimensions	P.896 to 901

Vacuum Pump System

How to Order	P.902
Combination of supply valve and release valve	P.904
Construction	P.905
Valve unit	P.906
Suction filter unit/Vacuum pressure switch unit	P.907
Dimensions/Combination of supply valve and release valve Type K1, K3, K6, K8	P.908 to 915
Manifold specifications	P.916
Dimensions	P.918 to 923

Unit Construction

Ejector system/Single, Manifold	P.924
Vacuum pump system/Single, Manifold	P.926
Manifold assembly from individual unit	P.928

Made to Order

1 2 Combinations of supply valve and release valve	P.930
3 High Noise Reduction Silencer Assembly	P.934

ZA
ZX
ZR
ZM
ZMA
ZQ
ZH
ZU
ZL
ZY□
ZF□
ZP□
SP
ZCUK
AMJ
AMV
AEP
HEP

Related Equipment

Series ZX

For electronic components and precision components up to 100 g

Modular design

Customized application function through selection of module components.

Compact size and lightweight (120 g with complete unit);
well suitable for actuator mounting

Ejector nozzle size: $\varnothing 0.5$ to $\varnothing 1.0$ (Suction flow: 5 to 22 L/min (ANR))

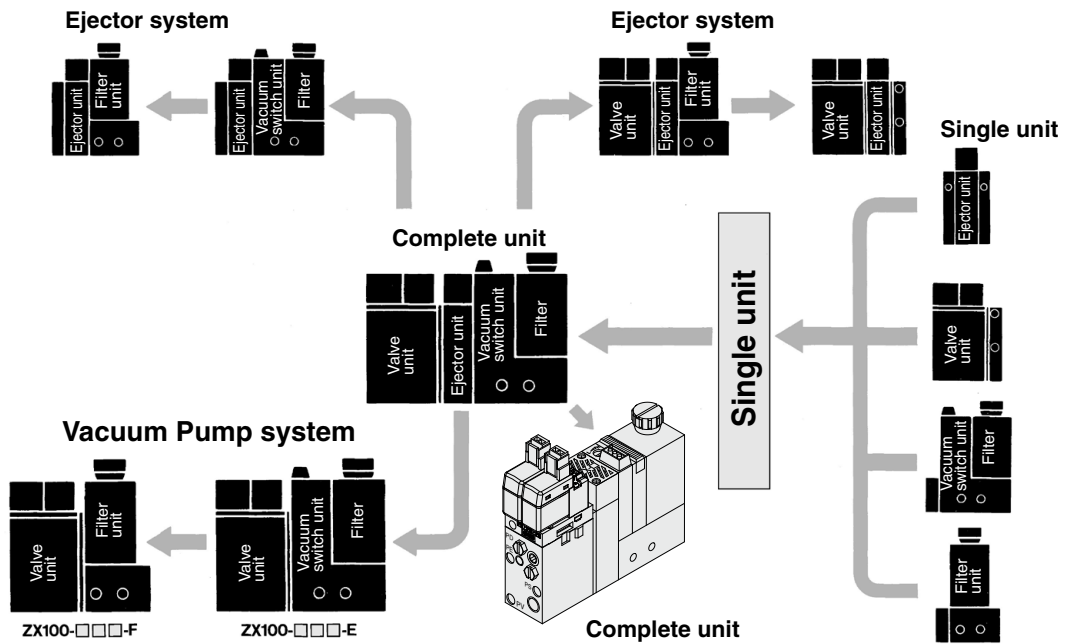

Application Example

Chip bonding

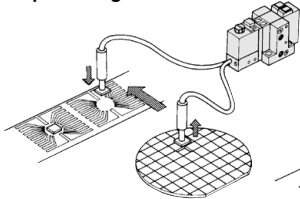

Chip mounting

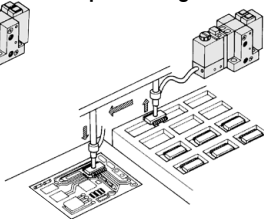

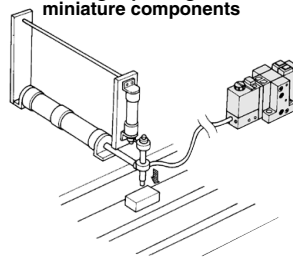

Picking & placing miniature components

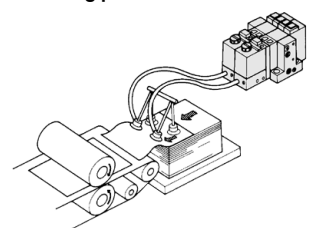

Escorting printed matter

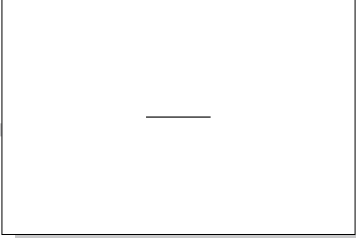
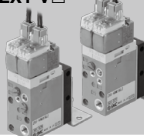
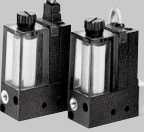

Modular Components Introduction

System		Ejector System	Vacuum Pump System
Component equipment	Characteristics	P.866 to 901	P.902 to 929
Ejector unit Series ZX1 	Nozzle diameter (mm)	0.5 0.7 1.0	
	Suction flow (L/min(ANR))	5 10 22	
	Air consumption (L/min(ANR))	13 23 46	
	Maximum vacuum pressure	-84 kPa	
	Exhaust release	Built-in silencer/Manifold exhaust Individual exhaust port: (Rc 1/8, 1/8-NPTF)	
Valve unit ZX1-V□ 	Component equipment	Supply valve/Release valve	
	Function	N.C., N.O.	
	Operation	Solenoid valve/Air operated valve	
	Power supply voltage	3, 5, 6, 12, 24 VDC, 100, 110 VAC (50/60 Hz)	
Vacuum pressure switch unit Series ZS 	Series	Vacuum switch	Vacuum switch
	Set pressure range	0 to -101 kPa	0 to -101 kPa
	Hysteresis	3% or less	0.5 kPa
	Applicable pad diameter (mm)	2 to 25	2 to 25
	Supply voltage	24 VDC	24 VDC
Suction filter unit ZX1-F 	Operating pressure range	Vacuum to 0.5 MPa	
	Filtration	30 μm	
Common specifications	Unit	Air supply port size	M5 (Standard)/M6 (Semi-standard)
		Vacuum pad connection port size	M5 (Standard)/M6 (Semi-standard)
	Manifold	Air supply port size	Rc 1/8
		Exhaust port size	Rc 1/8
		External pilot port size	M5
		Stations	Max. 8 units

- ZA
- ZX**
- ZR
- ZM
- ZMA
- ZQ
- ZH
- ZU
- ZL
- ZY□
- ZF□
- ZP□
- SP
- ZCUK
- AMJ
- AMV
- AEP
- HEP

Related Equipment

- Refer to pages 870 to 880 for detailed specifications for each unit.
- Refer to pages 866 and 867 for ejector system unit.
- Refer to page 894 for ejector system manifold.
- Refer to pages 902 and 903 for external vacuum supply system unit.

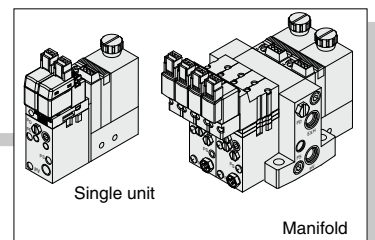
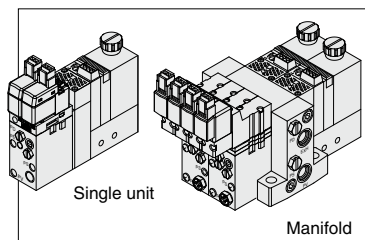

Made to Order
(Refer to pages 930 to 934 for details.)

- Refer to page 916 for external vacuum supply system manifold.
- Refer to pages 924 to 927 for units for replacement.

Vacuum Module: Ejector System Series ZX

Note) Refer to "How to Order"
for CE-compliant products.



How to Order

Components

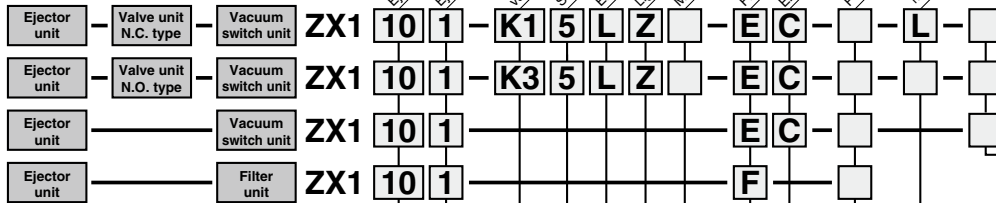

Ejector unit nozzle dia.

05	0.5 mm
07	0.7 mm
10	1.0 mm

Ejector exhaust

1	With silencer
2 ⁽¹⁾	Port exhaust Rc1/8
2T ⁽¹⁾	Port exhaust 1/8-NPTF
3 ⁽²⁾	Common exhaust (Manifold only)

Note 1) When port exhaust is applied to the manifold, pilot exhaust is done by common exhaust. Thus, the exhaust port on the manifold base should be open while operating.

Note 2) When the product is used for the manifold specification and common exhaust, the exhaust air of the operating ejector releases may enter the vacuum (V) port of the non-operating ejector and be released if there are an operating and non-operating ejector. Select either the built-in silencer or port exhaust for the ejector exhaust method.

Valve unit/Combination of supply valve and release valve
Refer to "Table (1)" on page 867.

Solenoid valve rated voltage

1 [*] (Note)	100 VAC 50/60 Hz	—
3 [*] (Note)	110 VAC 50/60 Hz	—
5	24 VDC	●
6	12 VDC	●
V	6 VDC	●
S	5 VDC	●
R	3 VDC	●
Nil	Air operated (K6, K8, J3, J4, D3, D4)	—

Note) CE-compliant products are not available for "1" and "3".

* Applicable to plug connector only. When replacing a product that uses a connector assembly with rectifier, replace the connector assembly as well. (Table (2) on page 867)

Electrical entry

L	L plug connector type	Lead wire length 0.3 m Without lead wire (Applicable to DC only)
LN	L plug connector type	Without connector
LO	L plug connector type	Without connector
M	M plug connector type	Lead wire length 0.3 m Without lead wire (Applicable to DC only)
MN	M plug connector type	Without connector
MO	M plug connector type	Without connector
G	Grommet type	Lead wire length 0.3 m (Applicable to DC only)
H	Grommet type	Lead wire length 0.6 m (Applicable to DC only)
Nil	Air operated	—

Note) In the case of "K1" or "J1" (combination of supply and release valves), M type plug connector can not be selected.

Caution

<For DC>
Grommet, L and M Plug Connector

With surge voltage suppressor

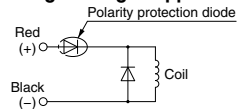

With light/surge voltage suppressor

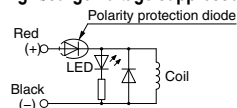

Match the polarity of the connectors according to the ⊕ and ⊖ marks on the connectors. Do not interchange the polarities to prevent the diodes or the switching elements from becoming burned.

If lead wires are pre-connected, the red wire is ⊕ and the black wire is ⊖.

<For AC>
L and M Plug Connector

With light (□Z)

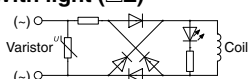

CE-compliant

Nil	—
Q	CE-compliant *

* Only for the model with solenoid valve or pressure switch

PV/V port size

Nil	M5 x 0.8
Y	M6 x 1 (Semi-standard)

* When the units are shipped as a manifold, the PV port is M5 x 0.8 with a plug.

Release flow rate adjusting needle/Bracket A

Nil	Lock nut	Bracket A
L	×	●
M	●	×
N	×	×

●: Attached (Bracket A is shipped together.) ×: None

Vacuum switch electrical entry

Nil	Grommet type	Lead wire length 0.6 m
L	Grommet type	Lead wire length 3 m
C	Connector type	Lead wire length 0.6 m
CL	Connector type	Lead wire length 3 m
CN	Connector type	Without connector (Without lead wire)

* Refer to "Table (3)" on page 867 for part number of lead wire with connector.

Vacuum switch unit/Filter unit

Nil	None	CE-compliant
E	Vacuum switch (For general purpose)/(ZSE2)/(NPN)	With suction filter
E55	Vacuum switch (For general purpose)/(ZSE2)/(PNP)	With suction filter
F	Only suction filter	—

Vacuum digital pressure switch unit (ZSE3)

D	21	2 outputs/without analog output
D	22	2 outputs/with analog output
D	23	1 output (with trouble detection)/without analog output
D	24	1 output (with trouble detection)/with analog output

Note) Analog output is available only on grommet type.

Manual operation

Nil	Non-locking push type
B	Locking slotted type

Light/Surge voltage suppressor

Nil	None
Z	With light/surge voltage suppressor
S*	With surge voltage suppressor

* S is not available for AC.

DC voltage (with surge voltage suppressor)
If the polarity is incorrect at DC (surge voltage suppressor), diode or switching element may be damaged.

- Refer to "Table (2)" on page 867 for part number of lead wire with connector.
- Refer to page 894 for ordering the manifold.
- Refer to pages 924 and 925 for ordering a unit for replacement.

The filter mounted on the product is a simplified one. When used in an environment with a lot of dust, the filter is likely to be clogged quickly. The use with the series ZFA, ZFB and ZFC is recommended.





Made to Order
(Refer to pages 930 to 934 for details.)

Table (1) Valve Unit/Combination of Supply Valve and Release Valve (Refer to page 868 for detailed specifications.)

Components		Symbol	Supply valve					Release valve					Weight (g)
Supply valve	Release valve		Solenoid valve		Air operated			Solenoid valve		Air operated	External release		
			N.C. (V114)	N.O. (SYJ324)	N.C. (ZX1A)	N.O. (SYJA324)	None	N.C. (V114)	N.C. (SYJ314)	N.C. (SYJA314)	ZX1A	None	
Solenoid (N.C.)	Solenoid (N.C.)	K1	●	—	—	—	—	●	—	—	—	—	79
Solenoid (N.O.)	Solenoid (N.C.)	K3	—	●	—	—	—	—	●	—	—	—	112
Air operated (N.C.)	External release	K6	—	—	●	—	—	—	—	—	●	—	53
Air operated (N.O.)	Air operated (N.C.)	K8	—	—	—	●	—	—	—	●	—	—	83
Solenoid (N.C.)	None	J1	●	—	—	—	—	—	—	—	—	●	64
Solenoid (N.O.)	None	J2	—	●	—	—	—	—	—	—	—	●	84
—		Nil	Without valve module										

- Air operated valve: Controlled by external 3 port valve.
- External release: Directly released by external 2 port valve.

Table (2) Valve Unit/Valve Plug Connector Assembly

For DC:
SY100-30-4A - 
For 100 VAC:
SY100-30-1A - 
For 110 VAC:
SY100-30-3A - 
Without lead wire:
(with connector and 2 sockets only)
SY100-30-A



Lead wire length	
Nil	0.3 m
6	0.6 m
10	1 m
15	1.5 m
20	2 m
25	2.5 m
30	3 m
50	5 m

How to order
If ordering vacuum module with 600 mm or the longer lead wire, specify both vacuum module and connector assembly part numbers.
Ordering example)
ZX1051-K15LOZ-EC(-Q) ... 1 pc.
*SY100-30-4A-6 2 pcs.
↳ The asterisk (*) denotes the symbol for assembly.

Warning

When replacing a product that uses a connector assembly with rectifier, replace the connector assembly as well.

Table (3) Vacuum Switch/Lead Wire with Connector

For ZSE2 **ZS-10-5A** - 
For ZSE3 **ZS-20-5A** - 

Note) If ordering a vacuum switch with 3 m lead wire, specify both the vacuum unit switch and the 3 m lead wire with connector part numbers.
Ordering example)
ZX1051-K15LO-ECN(-Q) ... 1 pc.
*SY100-30-4A-6 2 pcs.
*ZS-10-5A-50 1 pc.
↳ The asterisk (*) denotes the symbol for assembly.

Lead wire length	
Nil	0.6 m
30	3 m
50	5 m

Ejector System/Recommended Model (The models below will have shorter deliveries.)

Nozzle diameter (mm)	Model	Ejector unit exhaust type	Combination		Solenoid valve rated voltage	Lead wire electrical entry	Light/Surge voltage suppressor	Vacuum switch unit	Vacuum switch electrical entry
			Supply valve (Pilot valve)	Release valve (Direct operated)					
0.5	ZX1051-K15LZ-EC	With silencer	N.C. (V114)	N.C. (V114)	24 VDC	Plug connector type	With light/surge voltage suppressor	General vacuum switch (ZSE2)	Connector type
	ZX1051-K35MZ-EC		N.O. (SYJ324M)	N.C. (SYJ314)					
0.7	ZX1071-K15LZ-EC		N.C. (V114)	N.C. (V114)					
	ZX1071-K35MZ-EC		N.O. (SYJ324M)	N.C. (SYJ314)					
1.0	ZX1101-K15LZ-EC		N.C. (V114)	N.C. (V114)					
	ZX1101-K35MZ-EC		N.O. (SYJ324M)	N.C. (SYJ314)					

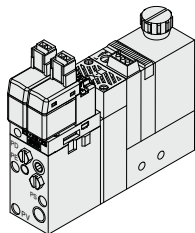

ZX1000-K15LZ-E0

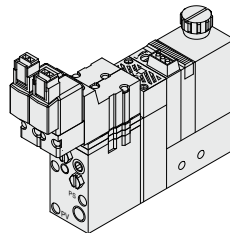

ZX1000-K35MZ-E0

ZA
ZX
ZR
ZM
ZMA
ZQ
ZH
ZU
ZL
ZY□
ZF□
ZP□
SP
ZCUK
AMJ
AMV
AEP
HEP

Related Equipment

Ejector System/Combination of Supply Valve and Release Valve

Combination Symbol: K1

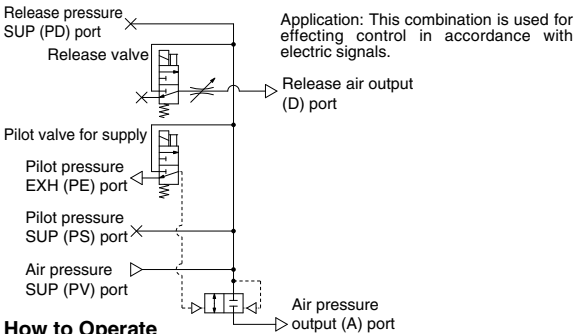

How to Operate

Condition	Valve	
	Supply valve (N.C.) Solenoid valve	Release valve (N.C.) Solenoid valve
1. Work adsorption	ON	OFF
2. Vacuum release	OFF	ON
3. Operation stop	OFF	OFF

Combination Symbol: K8

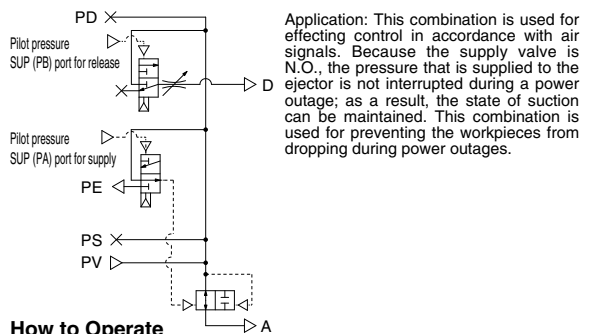

How to Operate

Condition	Valve	
	Supply valve (N.O.) Air operated valve	Release valve (N.C.) Air operated valve
1. Work adsorption	OFF	OFF
2. Vacuum release	ON	ON
3. Operation stop	ON	OFF

Combination Symbol: K3

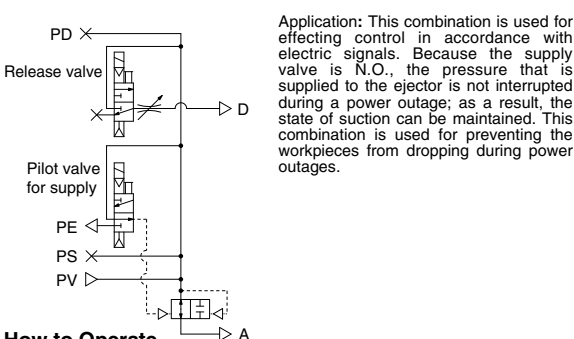

How to Operate

Condition	Valve	
	Supply valve (N.O.) Solenoid valve	Release valve (N.C.) Solenoid valve
1. Work adsorption	OFF	OFF
2. Vacuum release	ON	ON
3. Operation stop	ON	OFF

Combination Symbol: J1

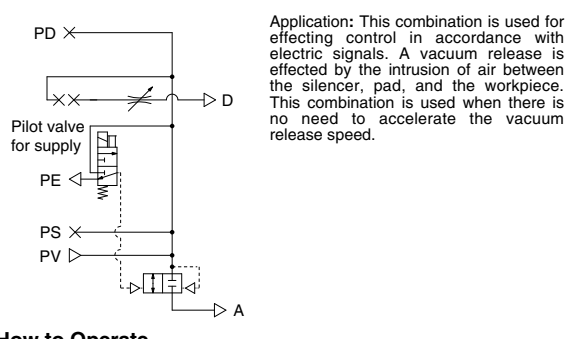

How to Operate

Condition	Valve	
	Supply valve (N.C.) Solenoid valve	Release valve None
1. Work adsorption	ON	—
2. Vacuum release	OFF	—
3. Operation stop	OFF	—

Combination Symbol: K6

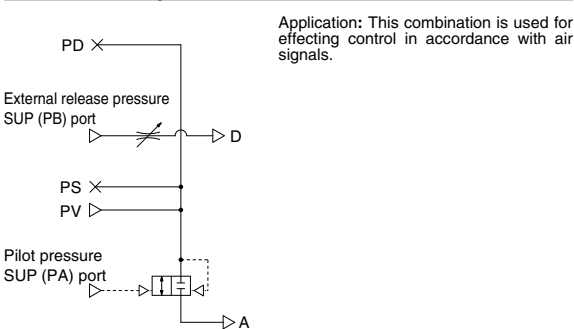

How to Operate

Condition	Valve	
	Supply valve External 3 port valve	Release valve External 2 port valve
1. Work adsorption	ON	OFF
2. Vacuum release	OFF	ON
3. Operation stop	OFF	OFF

Combination Symbol: J2

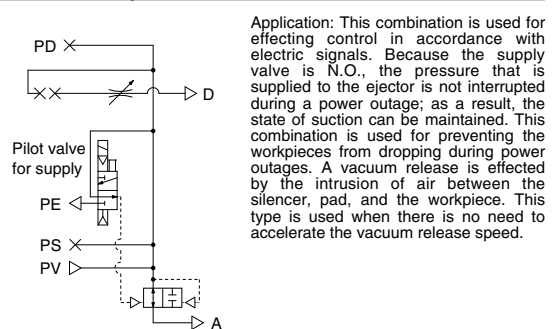

How to Operate

Condition	Valve	
	Supply valve (N.O.) Solenoid valve	Release valve None
1. Work adsorption	OFF	—
2. Vacuum release	ON	—
3. Operation stop	OFF	—

Ejector System/Construction

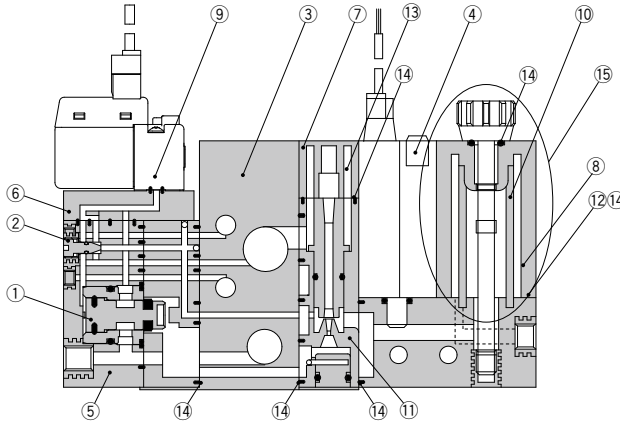

Component Parts

No.	Description	Material	Note
1	Poppet valve assembly	—	ZX1-PV-0
2	Release flow rate adjusting needle	Stainless steel	ZX1-NA
3	Manifold base	Aluminum	
4	Vacuum switch	—	ZSE2, ZSE3
5	Valve unit	—	ZX1-VA□□□□□□-D-□
6	Interface plate	—	(PV↔PS↔PD)
7	Silencer case	—	
8 ^{Note)}	Filter case	Polycarbonate	

Replacement Parts

No.	Description	Material	Part no.
9	Pilot valve Air operated	—	☉ Refer to "Table (1)", "(2)", "(3)".
10	Filter element	PVA	ZX1-FE
11	Ejector assembly	—	☉ Refer to "Table (4)".
12	Gasket	—	ZX1-FG
13	Silencer element	—	ZX1-SAE
14	Seal set	—	ZX1-PK
(7,13)	Silencer assembly	—	ZX1-HS2-□ (□: Nozzle diameter)
15	Filter case assembly	—	ZX1-FK-PC*

* Component parts
Filter case, filter element, tension bolt (including O-rings)
(Gasket 12 is not included.)

Note) Caution when handling filter case

- The case is made of polycarbonate. Therefore, do not use with or expose it to the following chemicals: paint thinner, carbon tetrachloride, chloroform, acetic ester, aniline, cyclohexane, trichloroethylene, sulfuric acid, lactic acid, watersoluble cutting oil (alkalanic), etc.
- Do not expose it to direct sunlight.

Table (1) How to Order Pilot Valves

No.	Components		Model	Combination of supply and release valve
	Supply valve	Release valve		
①	Solenoid valve N.C. (V114)	Solenoid valve N.C. (V114)	Z1-V114-□□□□	K1, J1
②	Solenoid valve N.O. (SYJ324M)	Solenoid valve N.C. (SYJ314)	ZX1-SYJ3 $\frac{1}{2}$ 4□-□□□□	K3, J2
③	Air operated N.O. (SYJA324)	Air operated N.C. (SYJA314)	ZX1-SYJA3 $\frac{1}{2}$ 4	K8
④	Air operated N.C. (ZX1A)		ZX1A-□	K6

Table (2) How to Order Solenoid Valves

● Supply valve (N.C.): K1, J1

Z1 - V114 - **5** **L** **Z** □

Manual override

Nil	Non-locking push type
B	Locking slotted type

● Supply valve (N.O.): K3, J2

Supply valve (N.O.)
ZX1 - SYJ324M - **5** **L** **Z** □

Release valve (N.C.)
ZX1 - SYJ314 - **5** **L** **Z** □

Rated voltage

1 ⁺	100 VAC
3 ⁺	110 VAC
5	24 VDC
6	12 VDC
V	6 VDC
S	5 VDC
R	3 VDC

* Applicable to plug connector only.

Electrical entry

L	Connector (0.3 m)
LN	Connector (without lead wire)
LO	Without connector
M⁺	Connector (0.3 m)
MN⁺	Connector (without lead wire)
MO⁺	Without connector
G	Grommet (0.3 m)
H	Grommet (0.6 m)

* In the case of Z1-V114, M, MN and MO cannot be selected.

Manual override

Nil	Non-locking push type
D	Locking slotted type

Light/Surge voltage suppressor

Nil	Without light/surge voltage suppressor
S⁺	With surge voltage suppressor
Z	With light/surge voltage suppressor

* S is not available for AC.

Table (3) How to Order Air Operated Valves

ZX1A - M5

Port size

M5	M5 x 0.8	Pilot port/ External release port
-----------	----------	--------------------------------------

Table (4) How to Order Ejector Assembly

ZX1-W D 05 1

Assembly no.

Ejector unit nozzle dia.

05	0.5 mm
07	0.7 mm
10	1.0 mm

Ejector type

(Exhaust type)

1	With silencer
2	Port exhaust Rc1/8
2T	Port exhaust 1/8-NPTF
3	Common exhaust

* An adapter should be attached to the assembly to be used as a unit. PV port and V port can be connected.

Ejector assembly □ • Combination/ ZX1-WD □
□ • Used as a unit by attaching an adapter/ ZX1-W □

⚠ Caution

Turning the vacuum release flow rate adjusting needle clockwise reduces the vacuum release flow volume; the needle valve is fully closed when the needle stops turning. Turning the needle 2 full turns counterclockwise from the fully closed position renders the needle valve fully open. The needle will fall out if it is turned more than 4 full turns.

In order to prevent the needle from loosening and falling out, the release flow rate adjusting needle with lock nut (ZX1-ND-L) is also available.

Ejector Unit

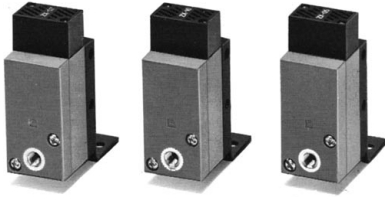

Specifications

Unit no.		ZX1-W05 ¹ _{2(T)}	ZX1-W07 ¹ _{2(T)}	ZX1-W10 ¹ _{2(T)}
Nozzle dia. (mm)		0.5	0.7	1.0
Suction flow (L/min (ANR))		5	10	22
Air consumption (L/min (ANR))		13	23	46
Vacuum pressure reached		-84 kPa		
Maximum operating pressure		0.7 MPa		
Supply pressure range		0.2 MPa to 0.55 MPa		
Standard supply pressure		0.45 MPa		
Operating temperature range		5 to 50°C		
Ejector exhaust type *		Code ①	Built-in silencer..... For single unit and manifold	
		Code ②	Port exhaust..... For single unit and manifold	
Weight	33 g	ZX1-W□1□ (With bracket)		Built-in silencer
	25 g	ZX1-W□1□-N (Without bracket)		
	37 g	ZX1-W□2□ (With bracket)		Port exhaust
	29 g	ZX1-W□2□-N (Without bracket)		

* Codes ① and ② are corresponding to the suffixes in "How to Order" to indicate the ejector exhaust method.

How to Order

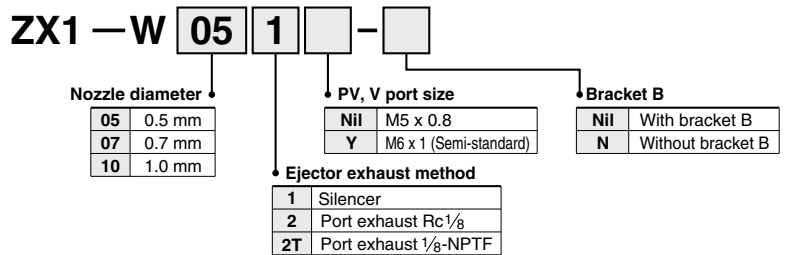

Dimensions: ZX1-W□□¹₂

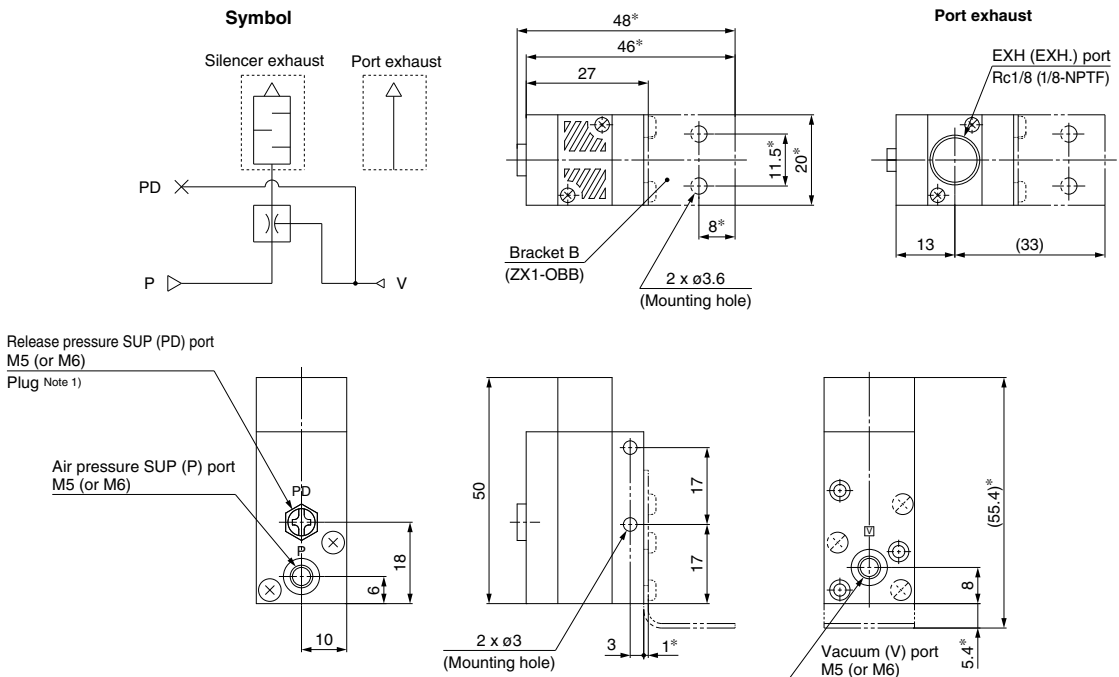

Note 1) Remove the plug at external release. Note 2) Dimensions *: For mounting bracket B.

Flow Rate Characteristics/Exhaust Characteristics

[At 0.45 MPa]

ZX1-W05

Exhaust Characteristics

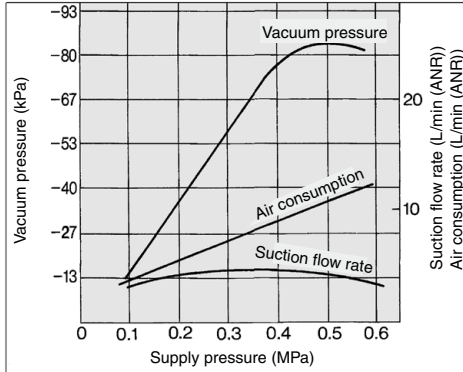

Flow Rate Characteristics

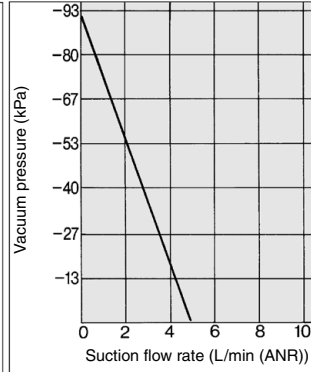

How to Read Flow Rate Characteristics Graph

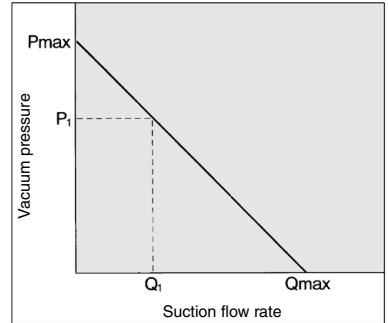

Flow Rate characteristics are expressed in ejector vacuum pressure and suction flow. If suction flow rate changes, a change in vacuum pressure will also be expressed. Normally this relationship is expressed in ejector standard use.

In graph, Pmax. is max. vacuum pressure and Qmax is max. suction flow. The valves are specified according to catalog use. Changes in vacuum pressure are expressed in the below order.

1. When ejector suction port is covered and made airtight, suction flow becomes 0 and vacuum pressure is at maximum value (Pmax).
2. When suction port is opened gradually, air can flow through, (air leakage), suction flow increases, but vacuum pressure decreases. (condition P₁ and Q₁)
3. When suction port is opened further, suction flow moves to maximum value (Qmax), but vacuum pressure is near 0. (atmospheric pressure).
When vacuum port (vacuum piping) has no leakage, vacuum pressure becomes maximum, and vacuum pressure decreases as leakage increases. When leakage value is the same as max. suction flow, vacuum pressure is near 0.
When ventirative or leaky work must be adsorbed, please note that vacuum pressure will not be high.

ZX1-W07

Exhaust Characteristics

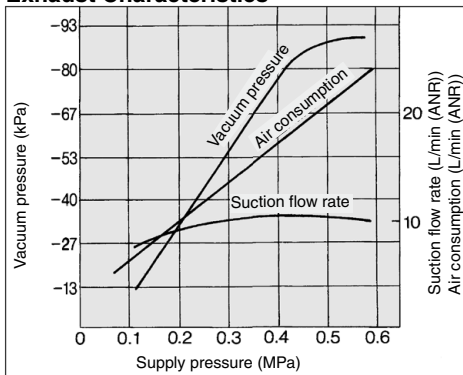

Flow Rate Characteristics

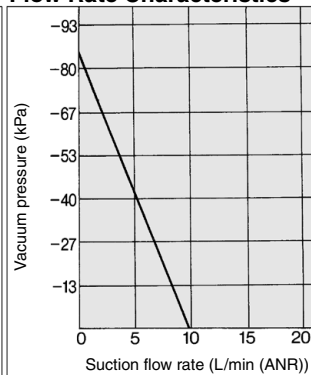

ZX1-W10

Exhaust Characteristics

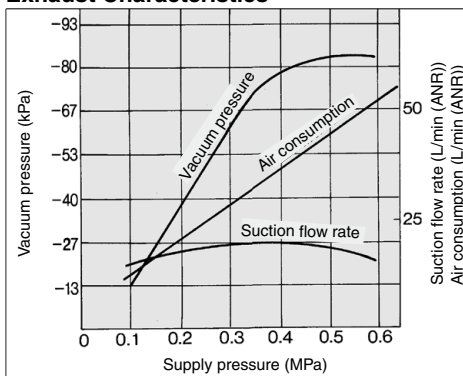

Flow Rate Characteristics

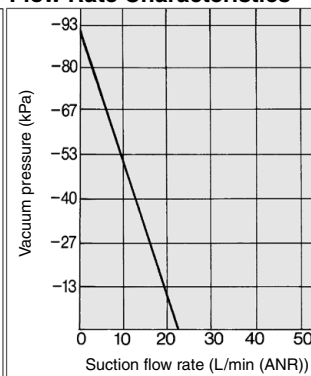

⚠ Precautions

Be sure to read before handling. Refer to front matters 38 and 39 for Safety Instructions and pages 844 to 846 for Vacuum Equipment Precautions.

⚠ Caution

Refer to the vacuum equipment model selection on pages 825 to 843 for the selection and sizing of Series ZX.

ZA
ZX
 ZR
 ZM
 ZMA
 ZQ
 ZH
 ZU
 ZL
 ZY □
 ZF □
 ZP □
 SP
 ZCUK
 AMJ
 AMV
 AEP
 HEP
 Related Equipment

Valve Unit: ZX1-VA

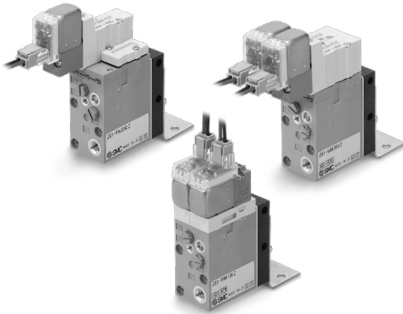

Model/Specifications

Unit no.	ZX1-VA□□□□□□(-Q)							
Components	Supply valve				Release valve			
	Pilot operated				Direct operated			
Operation	Solenoid valve		Air operated		Solenoid valve		Air operated	
	N.C. (V114)	N.O. (SYJ324M)	N.C. (ZX1A)	N.O. (SYJA324)	N.C. (SYJ314)	N.C. (V114)	External release (ZX1A)	N.C. (SYJA314)
Cv factor	0.17 Main valve				0.08	0.008	—	
Supply pressure range of air pressure SUP (PV) port	0.3 to 0.6 MPa							
Supply pressure range of pilot pressure SUP (PA, PB) ports for supply and release ^(Note)	PV port pressure to 0.6 MPa							
Max. operating frequency	5 Hz							
Operating temperature range	5 to 50°C							
Interface plate symbol	PV↔PS↔PD							

Note) Combination of supply valve and release valve: K4, K5, K6, K7, K8, J3, J4, D4

The supply and release valves of this product have a structure which uses the pressure of the air pressure SUP (PV) port to operate them. Be sure to supply a pressure that is the pressure of the air pressure SUP (PV) port or more and 0.6 MPa or less to the pilot pressure SUP (PA, PB) ports for supply and release.

Solenoid Valve Specifications

	V114	SYJ314, SYJ324M
Rated voltage	24, 12, 6, 5, 3 VDC/100, 110 VAC* (50/60 Hz)	
Electrical entry	L plug connector, grommet L plug connector, M plug connector, grommet	
Light/Surge voltage suppressor	With or Without	
Manual operation	Non-locking push type/Locking slotted type	

* Applicable to plug connector only.

How to Order /Refer to page 866 for details.

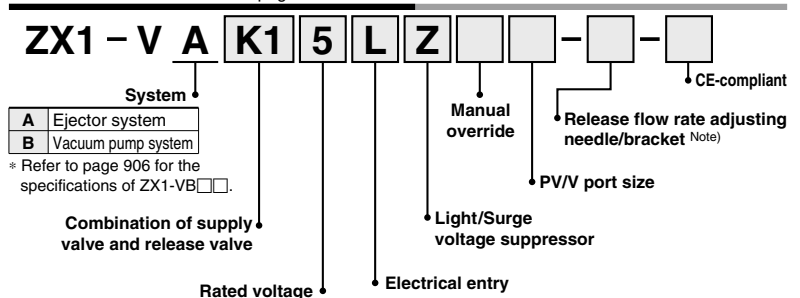

Note) For ZX1-VA (Valve unit): Bracket C
For ZX1-VB (Valve unit): Bracket B

Dimensions

Normally closed

A: Release flow rate adjusting needle with lock nut

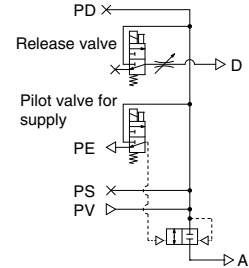
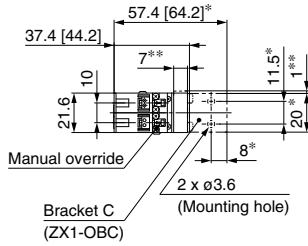
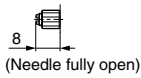
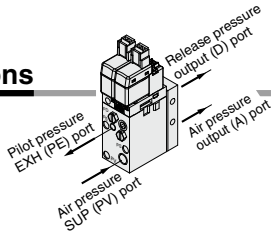

Circuit diagram

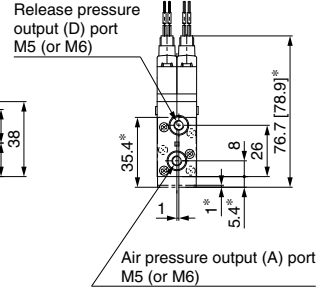
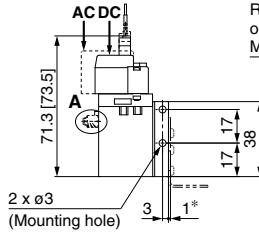
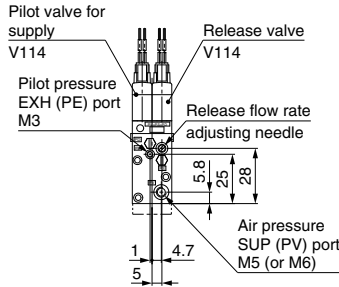

Normally open

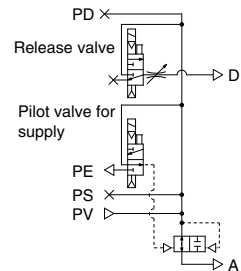
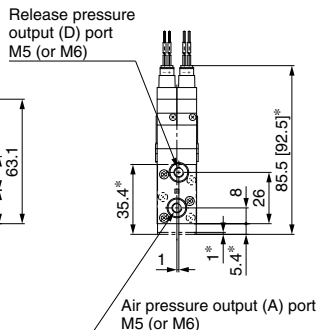
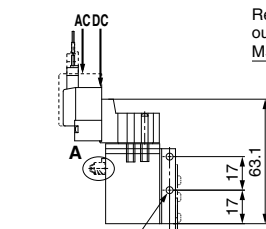
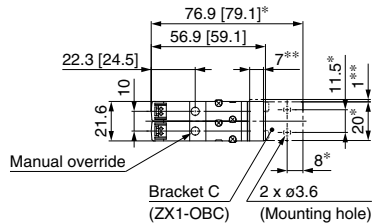
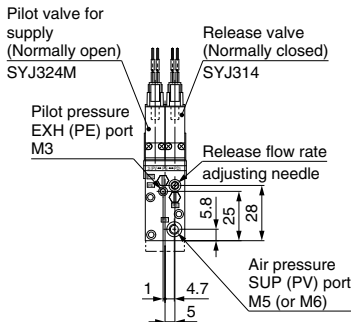

Circuit diagram

Note) Dimensions *: For mounting bracket C, **: For mounting spacer.

ZA
ZX
ZR
ZM
ZMA
ZQ
ZH
ZU
ZL
ZY□
ZF□
ZP□
SP
ZCUK
AMJ
AMV
AEP
HEP
Related Equipment

Suction Filter Unit: ZX1-F



Specifications

Unit no.		ZX1-F
Operating pressure range		—100 to 500 kPa
Operating temperature range		5 to 50°C
Filtration efficiency		30 μm
Element		PVA
Weight	37 g	ZX1-F-□ (With bracket A)
	29 g	ZX1-F-□-N (Without bracket A)

Note) If not operated within the specified range of pressure and temperature, trouble may result.

How to Order

ZX1 - F - □ - □

PV, V port size

Nil	M5 x 0.8
Y	M6 x 1 (Semi-standard)

Bracket

Nil	With bracket A
N	Without bracket A

Dimensions

Symbol

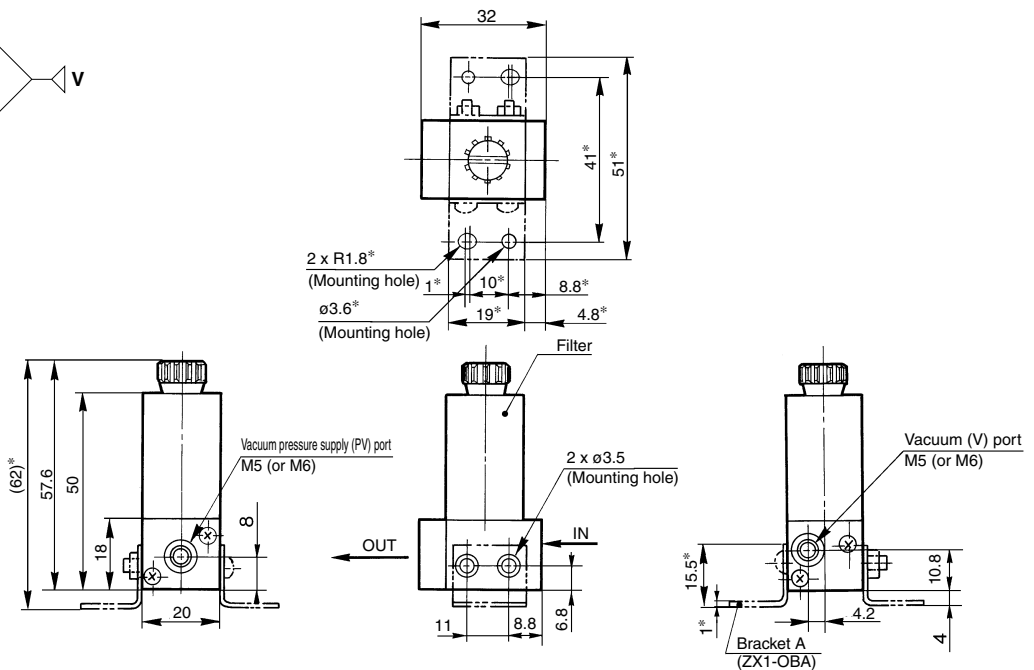
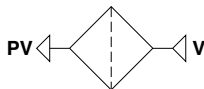

Note) Dimensions *: For A mounting bracket.

Filter case

⚠ Caution

1. The case is made of polycarbonate. Therefore, do not use it with or expose it to the following chemicals: paint thinner, carbon tetrachloride, chloroform, acetic ester, aniline, cyclohexane, trichloroethylene, sulfuric acid, lactic acid, water-soluble cutting oil (alkalinic), etc.

2. Do not expose it to direct sunlight.

About this product

The filter mounted on the product is a simplified one. When used in an environment with a lot of dust, the filter is likely to be clogged quickly. Select a large-volume filter such as Series ZFA, ZFB, ZFC.

Vacuum Pressure Switch Unit/Vacuum Pressure Switch: ZSE2-0X

Quick response: 10 ms

Compact size: 39H x 20W x 15D
(except the connecting portion
of the standard type)

Improved wiring: connector type

Uses a carrier diffusion
semiconductor pressure sensor

Pressure detector
(A carrier diffusion semiconductor
pressure sensor is used.)

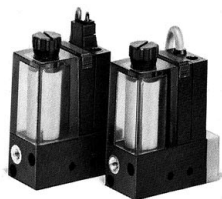
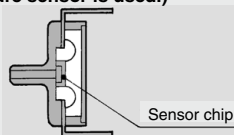

Vacuum Pressure Switch

Unit no.	ZSE2-0X
Fluid	Air
Set pressure range	0 to -101 kPa
Hysteresis	3% Full span or less
Repeatability	±1% Full span or less
Temperature characteristics	±3% Full span or less
Voltage	12 to 24 VDC (Ripple ±10% or less)
Port size	M5 x 0.8, M6 x 1 (Semi-standard)
Output	Open collector 30 V, 80 mA
Indicator light	Light at ON state
Current consumption	17 mA or less (24 VDC, at ON state)
Operating temperature range	0 to 60°C
Max. operating pressure	0.5 MPa *

* When using ejector system, instantaneous pressure up to 0.5 MPa will not damage the switch.
Note) If not operated within the specified range of pressure of temperature, trouble may result.

Wiring

ZSE2 connection

-15NPN Open collector

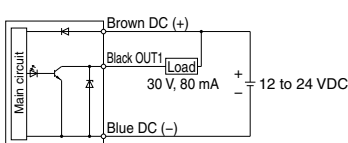

-55PNP Open collector

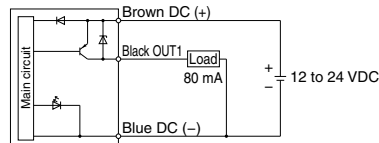

How to Order

ZSE2 - 0X [] - 15 [] []

PV, V port size

Nil	M5 x 0.8
Y	M6 x 1 (Semi-standard)

Electrical entry

Nil	Grommet (0.6 m) [40]
L	Grommet (3 m) [95]
C	Connector (0.6 m) [35]
CL	Connector (3 m) [75]
CN	Without connector [30]

Output specifications

15	NPN Open collector 30 V 80 mA
55	PNP Open collector 30 V 80 mA

[]: Weight (g)

• Filter case

⚠ Caution

1. The case is made of polycarbonate.

Therefore, do not use it with or expose it to the following chemicals: paint thinner, carbon tetrachloride, chloroform, acetic ester, aniline, cyclohexane, trichloroethylene, sulfuric acid, lactic acid, water-soluble cutting oil (alkalinic), etc.

2. Do not expose it to direct sunlight.

• Vacuum pressure setting

⚠ Caution

Observe the following precautions when setting the vacuum pressure.

Lightly turn the screwdriver with your fingertips.

To prevent damage to the trimmer groove, do not use a screwdriver that has a large grip or a tip that does not fit in the trimmer groove.

The filter mounted on the product is a simplified one. When used in an environment with a lot of dust, the filter on the unit is likely to be clogged quickly. Use with the ZFA, ZFB and ZFC series is recommended.

Refer to the pressure switch ZSE2 Series catalog for the detailed specifications of pressure switches.

How to Set Vacuum Pressure

ZSE2

- Pressure setting trimmer selects the ON pressure. Clockwise rotation increases high vacuum set point.

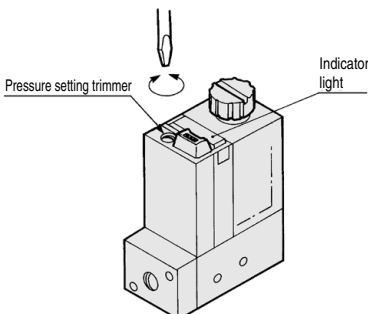

- When using the switch to confirm correct adsorption, the set pressure should be as low as possible. If setting the pressure lower than that, switch becomes ON in case when adsorption is not complete. If setting the pressure higher than that, switch does not become ON though it is absorbing workpieces properly.

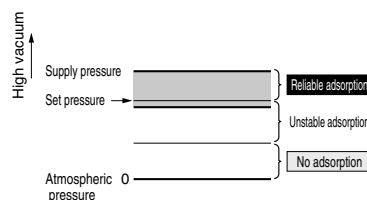

Vacuum Pressure Switch Unit/Vacuum Pressure Switch: ZSE2-0X

Guidelines for Use of Vacuum Pressure Switch Unit

System circuit for work adsorption

Ejector style

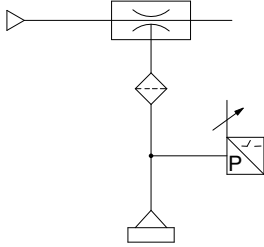

Vacuum pump style

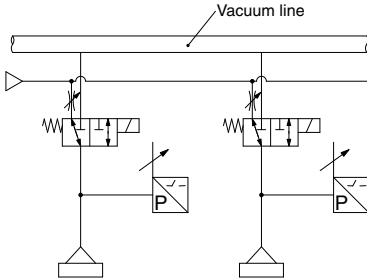

Set pressure

To use for picking verification, set a vacuum pressure that can pick the workpiece without fail.

Vacuum pump system

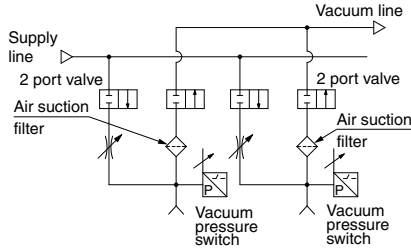

Using multiple pressure switches with a single vacuum source

If a single vacuum source is divided so that vacuum switches can be used on individual lines, the vacuum pressure might not come within the values set with the switches because the pressure of the vacuum source fluctuates depending on the number of picks and non-picks. Especially, because pressure fluctuation exerts a great influence when picking with a small diameter nozzle, the countermeasures described below must be provided.

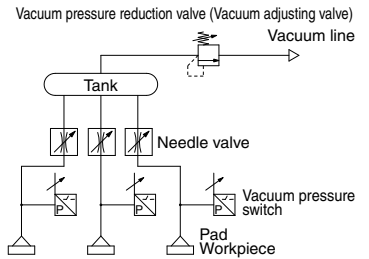

- Adjust the needle valve to reduce the pressure fluctuation between picking and non-picking.
- Stabilize the source pressure by providing a tank and a vacuum regulator.
- Provide a vacuum switch valve to individual lines. Thus, in case of an error, each valve can be turned OFF to minimize the influences on other pads.

Dimensions

Grommet: ZSE2-0X-15₅₅

Symbol

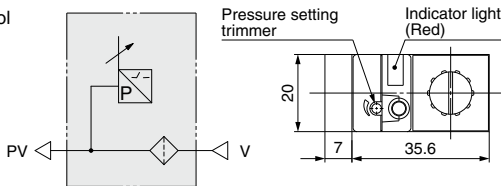

Connector: ZSE2-0X-15₅₅C

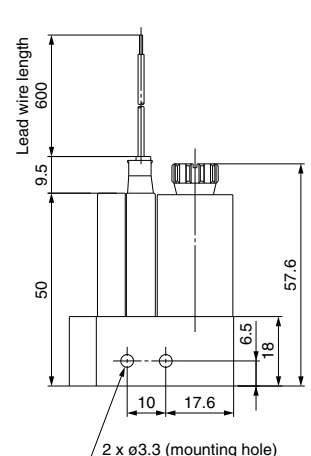
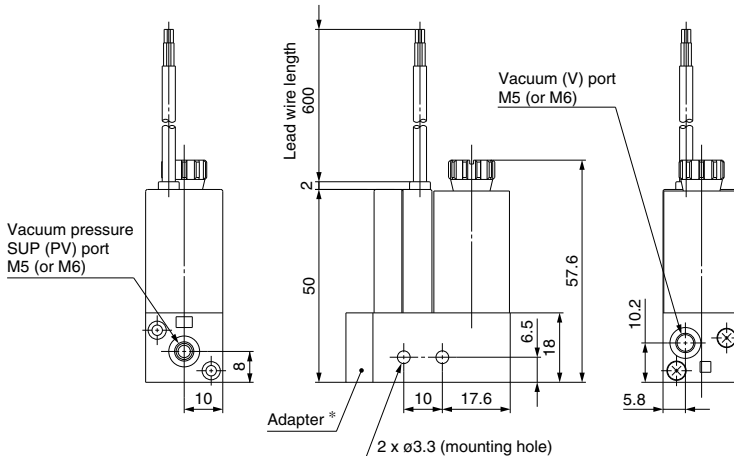
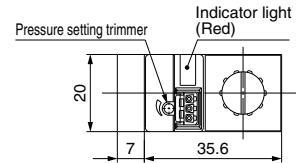

Vacuum Pressure Switch Unit/Vacuum Pressure Switch: ZSE3-0X

Built-in failure prediction output function

If the attainable amount of vacuum reduces due to a decrease in performance caused by clogging of the silencer of the vacuum system (ejectors), cracked pads, or the leakage of the vacuum pipes, this function quickly detects the abnormal condition and outputs a signal to halt the system.

Two independent pressure settings are possible

This feature is well suited for applications that require 2 separate pressure outputs due to a change in the vacuum suction pad diameters, or for applications that require 2 pressure verifications to effect line changes in the positive pressure line.

Comprehensive self diagnosis function

- Overcurrent detection function
- Overvoltage detection function
- Data error

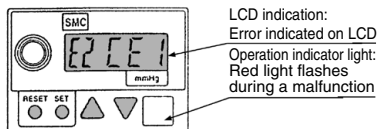

Data saving function

Even if the power is cut off, the settings are stored for 100,000 hours (approximately 11 years) in the exclusive IC (EEPROM).

• Filter case

⚠ Caution

1. The case is made of polycarbonate. Therefore, do not use it with or expose it to the following chemicals: paint thinner, carbon tetrachloride, chloroform, acetic ester, aniline, cyclohexane, trichloroethylene, sulfuric acid, lactic acid, water-soluble cutting oil (alkalinic), etc.
2. Do not expose it to direct sunlight.

Vacuum Pressure Switch

Unit no.		ZSE3-0X
Fluid		Air
Set pressure range		0 to -101 kPa
Hysteresis	Hysteresis mode	Variable (Can be changed from 0)
	Window comparator mode	Fixed (3 digits)
Accuracy		±1% Full span or less
Operating voltage		12 to 24 VDC (Ripple ±10% or less)
Port size		M5 x 0.8, M6 x 1 (Semi-standard)
Indicator light		Light at ON state
Current consumption		25 mA or less
Operating temperature range		0 to 60°C
Max. operating pressure		0.5 MPa

Wiring

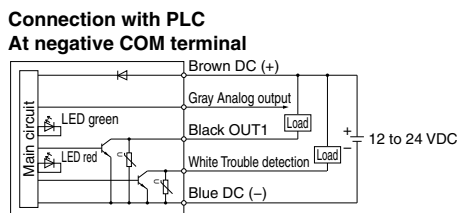
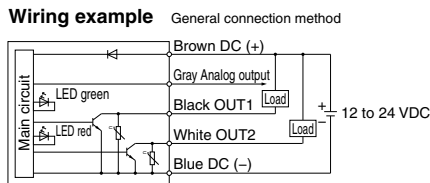

How to Order

ZSE3 - 0X - **21**

PV, V port size

Nii	M5 x 0.8
Y	M6 x 1 (Semi-standard)

Output specifications

21	NPN open collector, double output Without analog output
22	NPN open collector, double output With analog output
23	NPN open collector 1 output/Trouble detection/ Without analog output
24	NPN open collector 1 output/Trouble detection/ With analog output

Wiring specifications

Nii	Grommet (0.6 m) [75]
L	Grommet (3 m) [140]
C	Connector (0.6 m) [75]
CL	Connector (3 m) [140]
CN	Without connector [70]

Note) Analog output is available only for grommet type.
[]: Weight (g)

How to Set Vacuum Pressure

Refer to Best Pneumatics No. 6.

Guidelines for Use of Vacuum Pressure Switch Unit

Refer to page 876.

Vacuum Pressure Switch Unit/Vacuum Pressure Switch: ZSE3-0X

Dimensions

Grommet: ZSE3-0X□-□

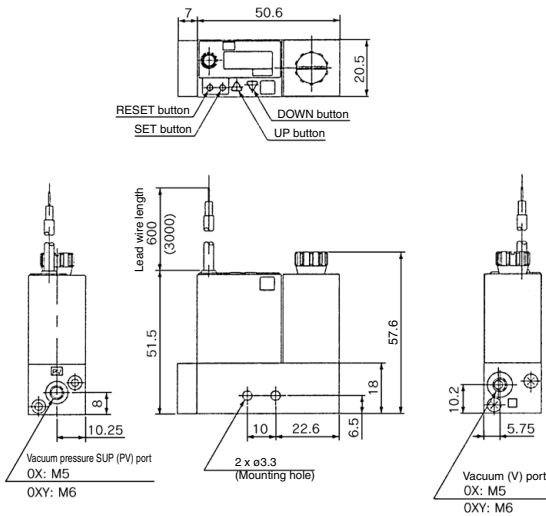

Connector: ZSE3-0X□-□C

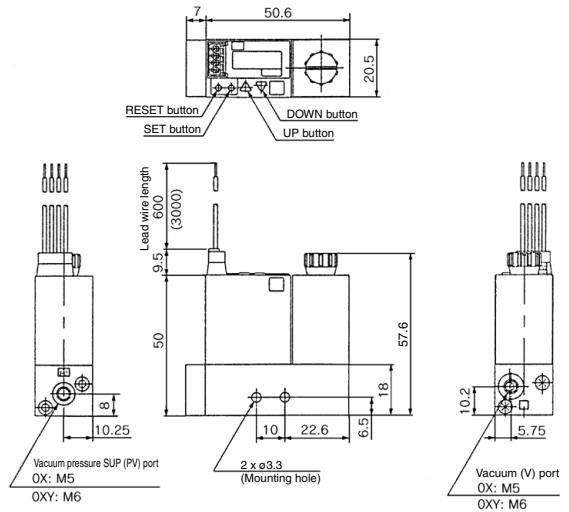

Symbol

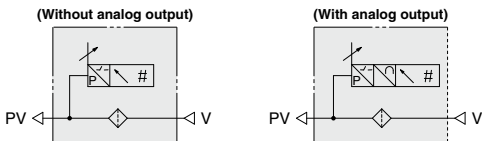

ZA

ZX

ZR

ZM

ZMA

ZQ

ZH

ZU

ZL

ZY□

ZF□

ZP□

SP

ZCUK

AMJ

AMV

AEP

HEP

Related
Equipment

Without Valve Unit

Configuration and combination

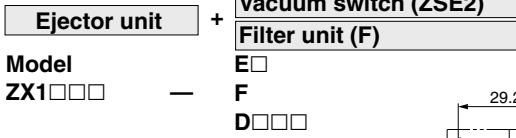

Vacuum switch (ZSE2)
 ZX1□□□-E□

Circuit diagram

(Circuits other than those with vacuum switch are shown as below.)

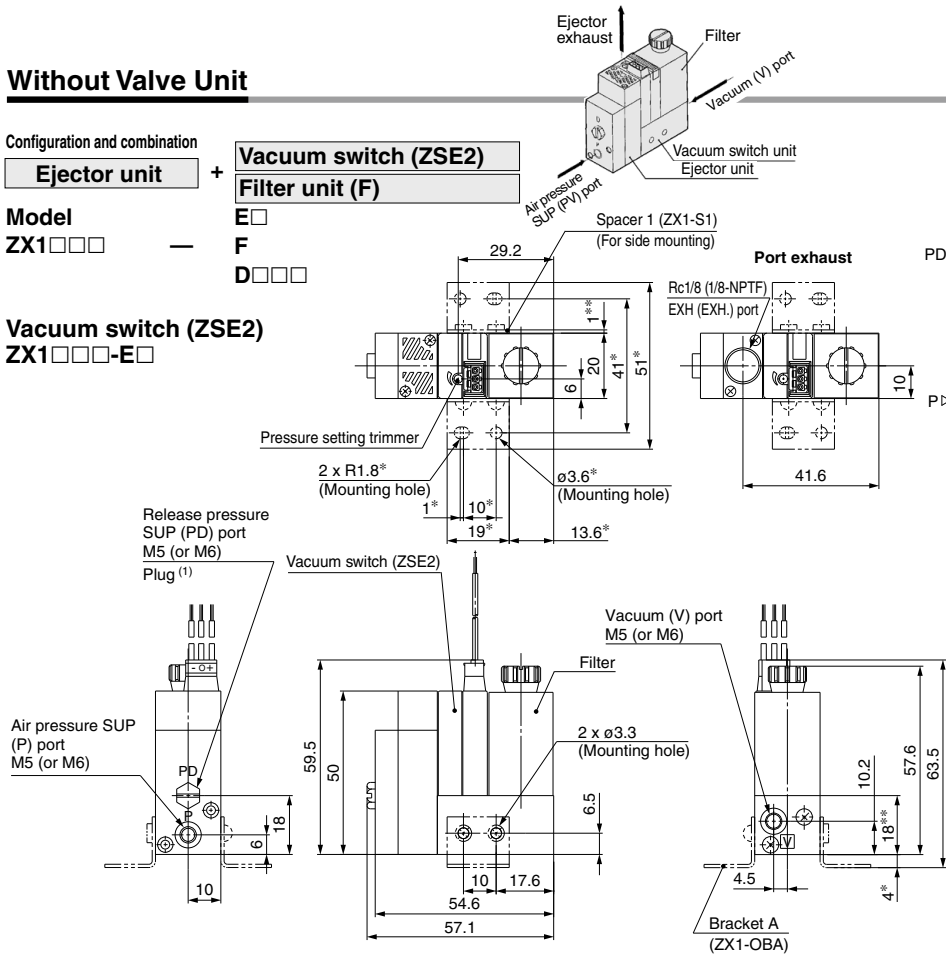
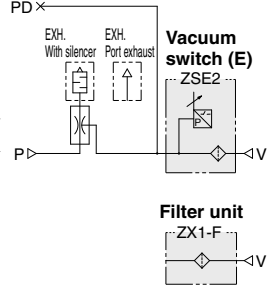

Note 1) Remove the plug at external release.

Note 2) Dimensions *: For mounting bracket A **: For mounting spacer 1.

Filter unit (F)
 ZX1□□□-F

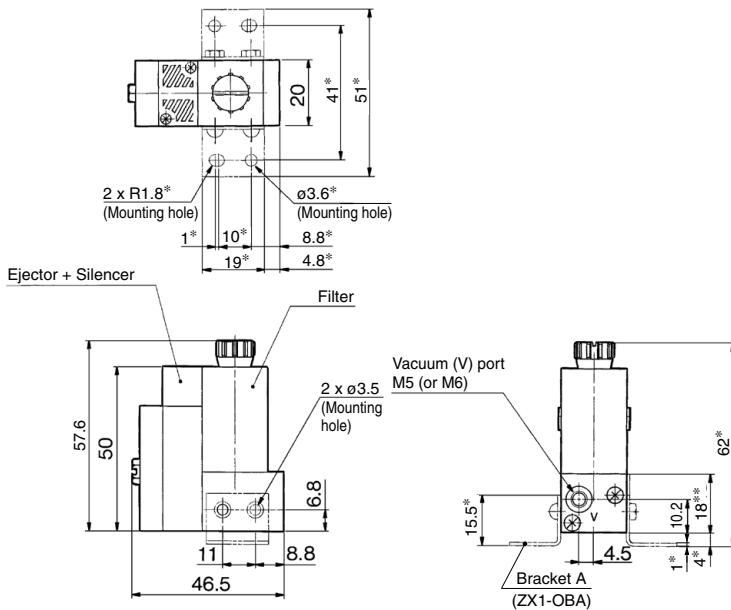

ZA
ZX
ZR
ZM
ZMA
ZQ
ZH
ZU
ZL
ZY□
ZF□
ZP□
SP
ZCUK
AMJ
AMV
AEP
HEP
Related Equipment

Series ZX

Valve Unit: Type K1

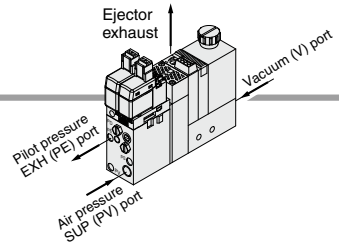

Configuration and combination

Ejector unit + Valve unit (K1) +

- Vacuum switch (ZSE2)
- Vacuum switch (ZSE3)
- Filter unit (F)
- Without switch and filter

Model

ZX1□□□ — K1□□□□ —

- E□
- D□□□
- F□
- Nil

Vacuum switch (ZSE2)

ZX1□□□-K1□□□□-E□

Port exhaust

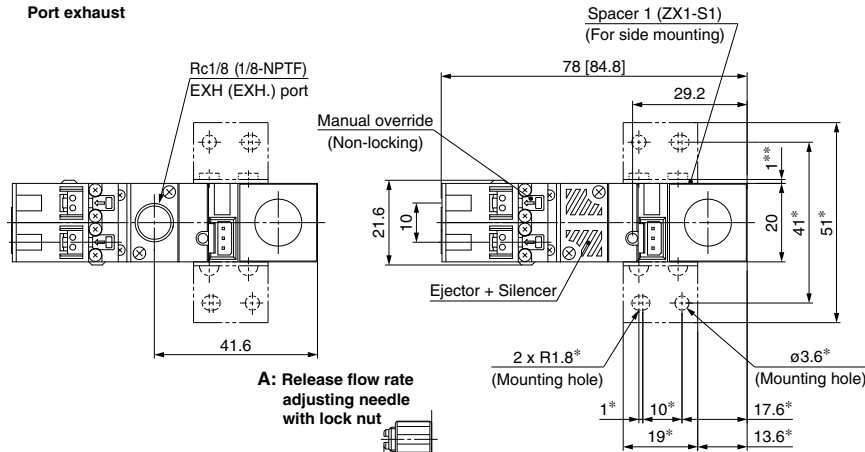

A: Release flow rate adjusting needle with lock nut

8
(Needle fully open)

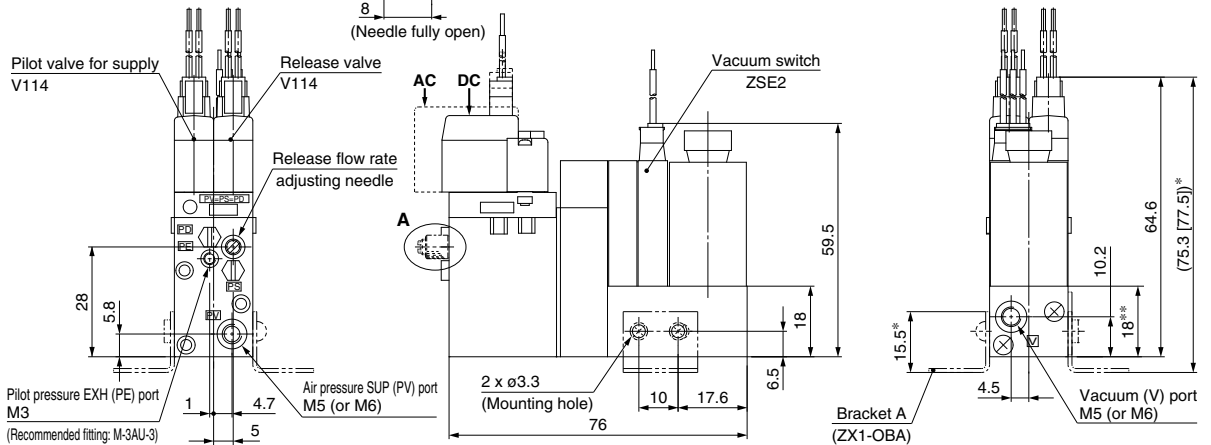

Note) Dimensions *: For mounting bracket A **: For mounting spacer 1.

Circuit diagram

(Circuits other than those with vacuum switch are shown as below.)

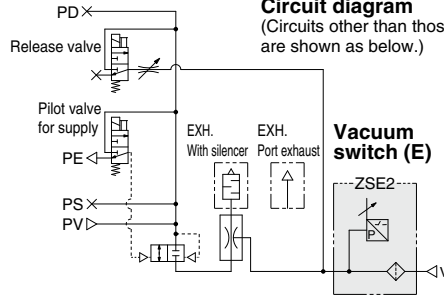

Vacuum digital pressure switch (D)

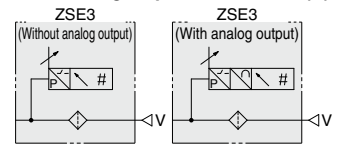

Filter unit

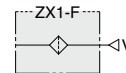

Without switch and filter

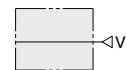

Series ZX

Valve Unit: Type K3

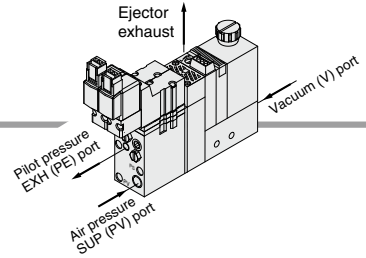

Configuration and combination Ejector unit + Valve unit (K3) +	Vacuum switch (ZSE2)
	Vacuum switch (ZSE3)
	Filter unit (F)
	Without switch and filter

Model
 ZX1□□□□ — K3□□□□ —
 E□
 F□□□
 D□□□
 Nil

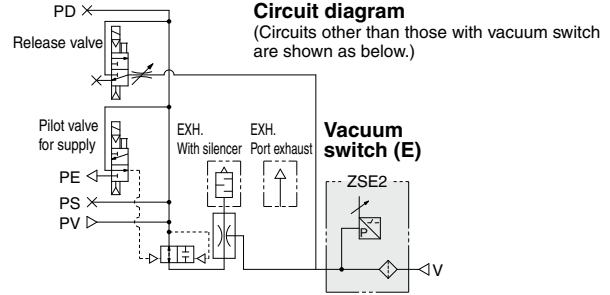

Vacuum switch (ZSE2)
 ZX1□□□□-K3□□□□-E□

Vacuum digital pressure switch (D)

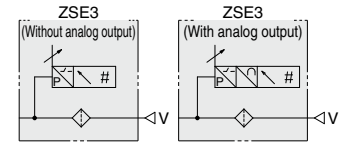

Filter unit

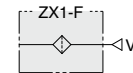

Without switch and filter

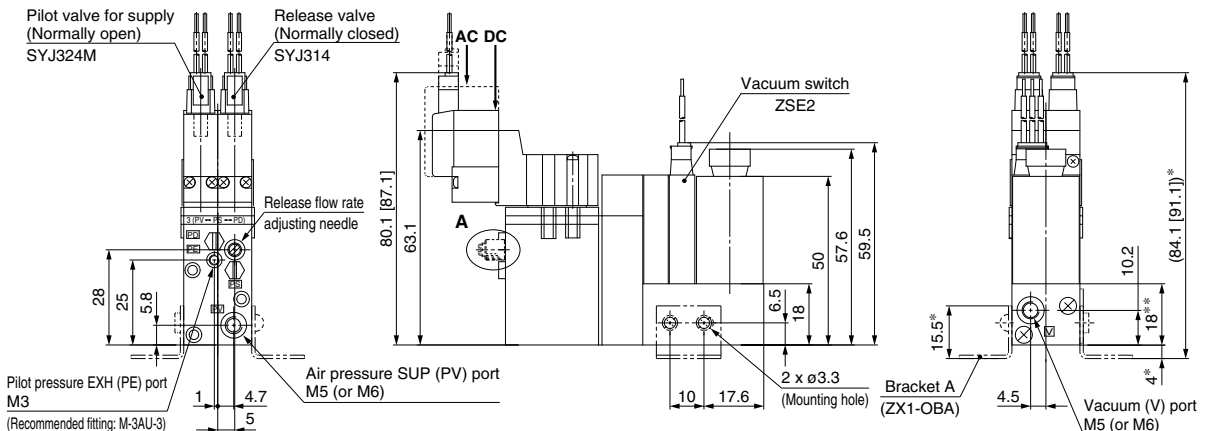
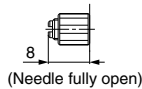
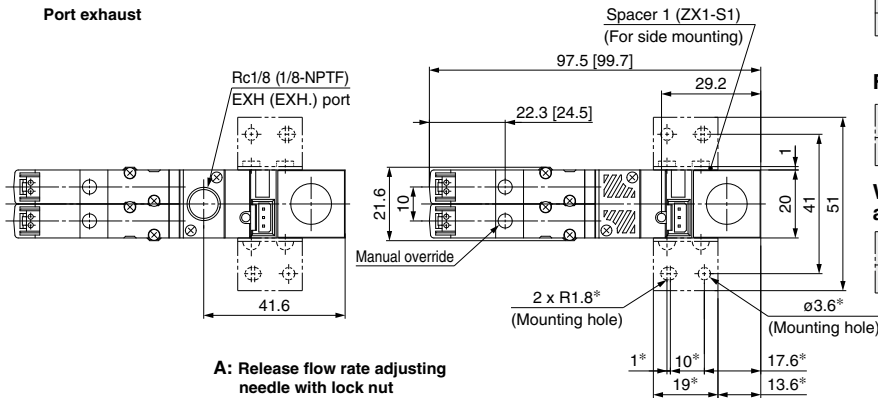
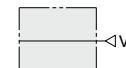

Note) Dimensions *: For mounting bracket A **: For mounting spacer 1.

[]: AC

Filter unit (F)
ZX□□□-K3□□□□-F

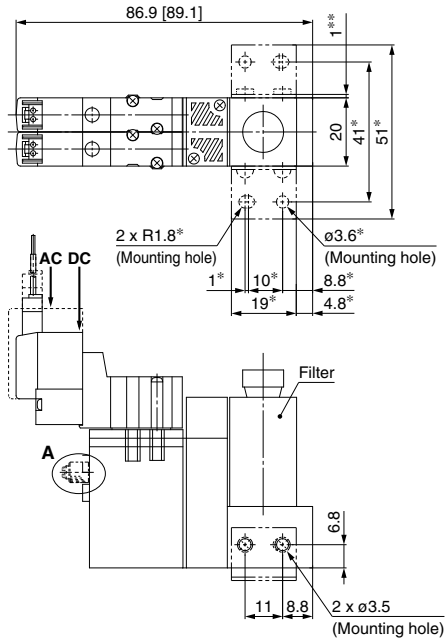

Spacer 1: ZX1-S1

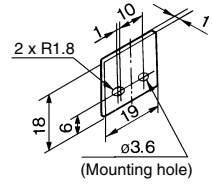

Without switch and filter
ZX1□□□-K3□□□□

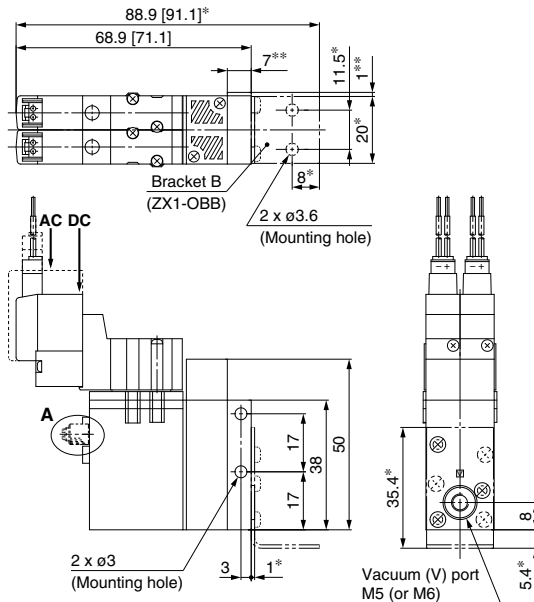

- ZA
- ZX**
- ZR
- ZM
- ZMA
- ZQ
- ZH
- ZU
- ZL
- ZY□
- ZF□
- ZP□
- SP
- ZCUK
- AMJ
- AMV
- AEP
- HEP
- Related Equipment

Filter unit (F)
ZX1□□□-K6-F

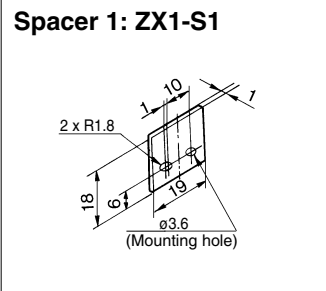
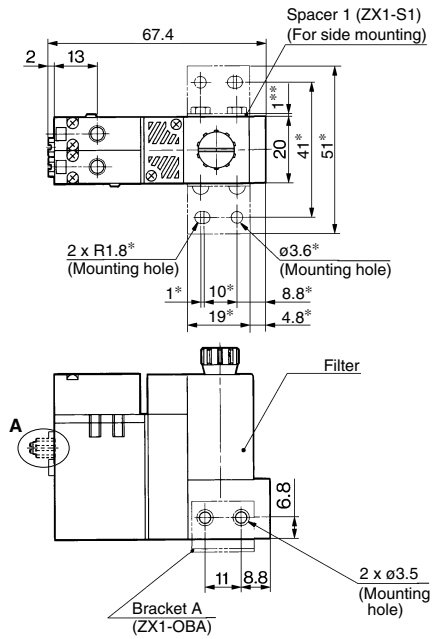

- ZA
- ZX**
- ZR
- ZM
- ZMA
- ZQ
- ZH
- ZU
- ZL
- ZY□
- ZF□
- ZP□
- SP
- ZCUK
- AMJ
- AMV
- AEP
- HEP

Related Equipment

Without switch and filter
ZX1□□□-K6

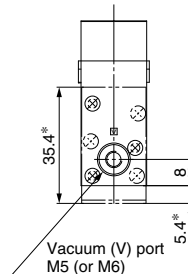
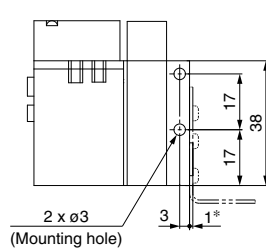
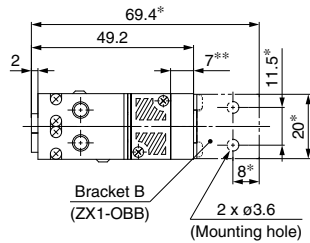

Series ZX

Valve Unit: Type J1

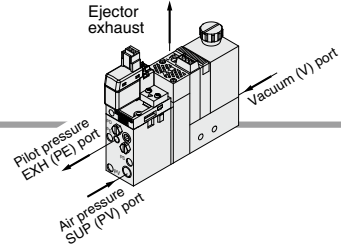

Configuration and combination

Ejector unit + Valve unit (J1) +

- Vacuum switch (ZSE2)
- Vacuum switch (ZSE3)
- Filter unit (F)
- Without switch and filter

Model

ZX1□□□ — J1□□□□ —

- E□
- F□
- D□□□
- Nil

Vacuum switch (ZSE2)

ZX1□□□-J1□□□□-E□

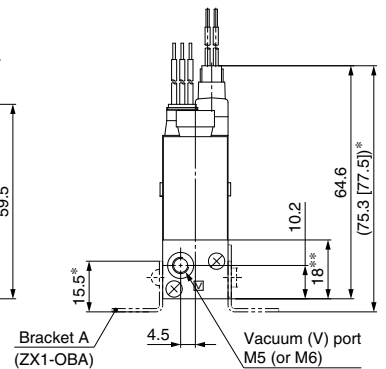
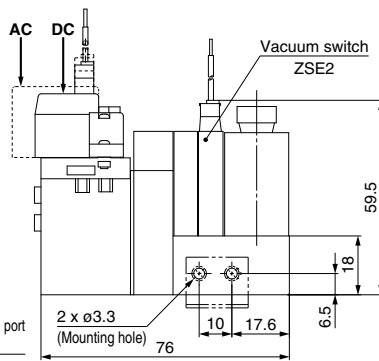
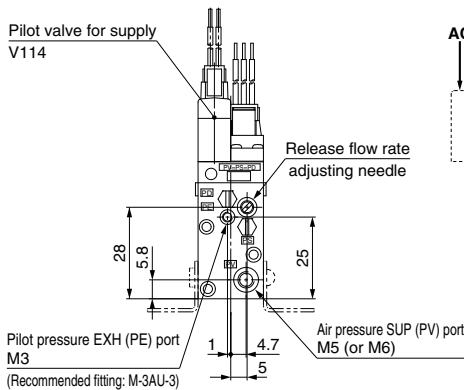
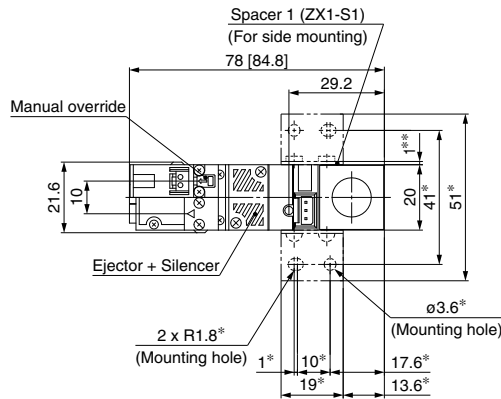
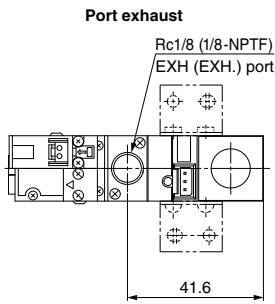

Note) Dimensions *: For mounting bracket A **: For mounting spacer 1.

Circuit diagram

(Circuits other than those with vacuum switch are shown as below.)

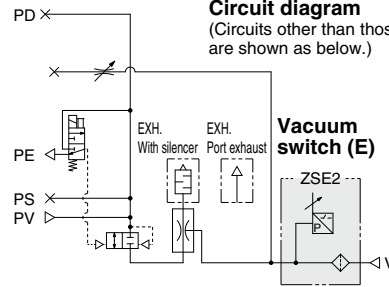

Vacuum digital pressure switch (D)

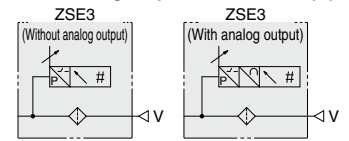

Filter unit

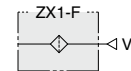

Without switch and filter

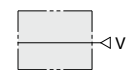

Filter unit (F)
ZX1□□□-J1□□□□-F

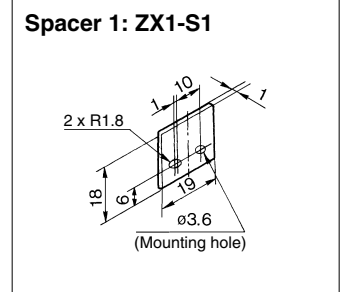
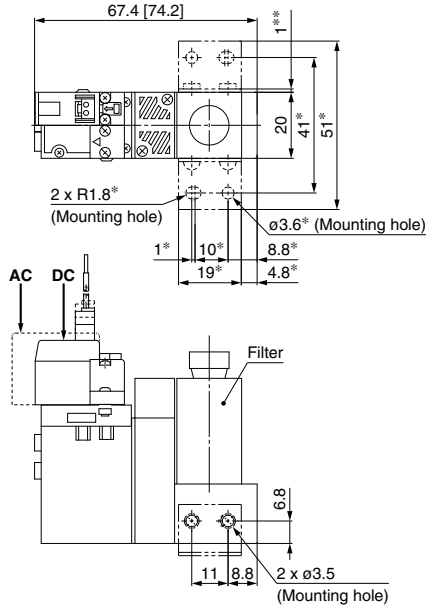

Without switch and filter
ZX1□□□-J1□□□□

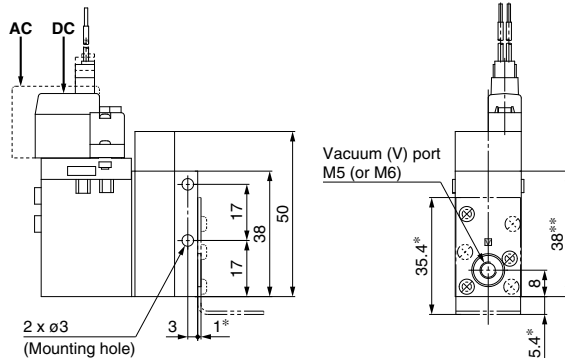
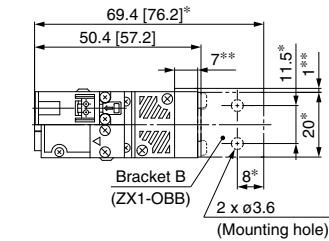

- ZA
- ZX**
- ZR
- ZM
- ZMA
- ZQ
- ZH
- ZU
- ZL
- ZY□
- ZF□
- ZP□
- SP
- ZCUK
- AMJ
- AMV
- AEP
- HEP

Related Equipment

Filter unit (F)
ZX1□□□-J2□□□□-F

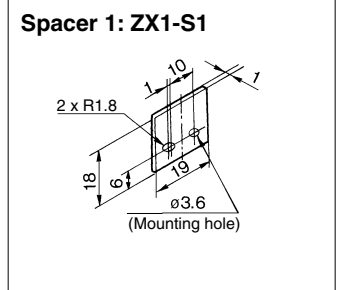
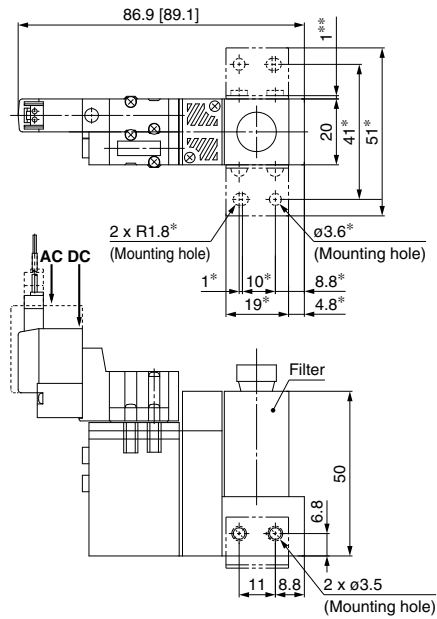

Without switch and filter
ZX1□□□-J2□□□□

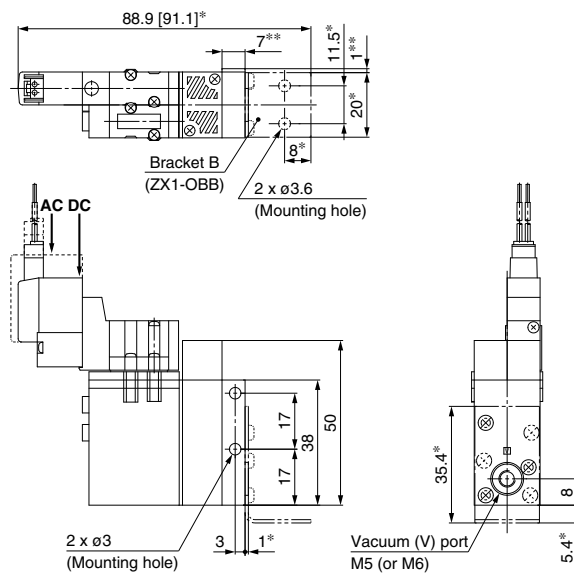

- ZA
- ZX**
- ZR
- ZM
- ZMA
- ZQ
- ZH
- ZU
- ZL
- ZY□
- ZF□
- ZP□
- SP
- ZCUK
- AMJ
- AMV
- AEP
- HEP
- Related Equipment

Ejector System/Manifold Specifications

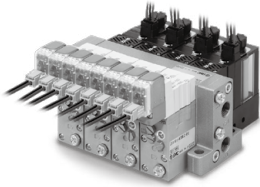
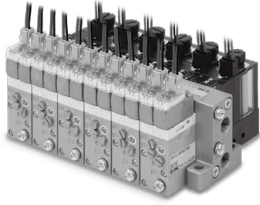

Specifications

Max. number of units		Max. 8 units
Port size	Supply port [PV]	1/8 (Rc, NPT, G)
	Exhaust port [EXH]	1/8 (Rc, NPT, G)
Weight		1 station: 114 g (45 g per additional station)

Note 1) PD port: Blank

Note 2) Exhaust air from both sides for 4 or more stations of ZX1103 manifold.

Air Supply

Supply port location	Manifold Port		Left side		Right side	
	PV	PS	PV	PS	PV	PS
L (Left)	○	●	○	●	●	●
R (Right)	●	●	●	●	○	●
B (Both sides)	○	●	○	●	○	●

○ : Supply ● : Plugged (EXH port is released to atmospheric pressure.)

Note) Blank plugs are attached to all ports of each valve unit.

How to Order Manifold

<Manifold base>

ZZX1 06 - [] R

Stations	
01	1
02	2
⋮	⋮
08	8

Supply port location *1)	
R	Right side (PV port on the right side)
L	Left side (PV port on the left side)
B	Both sides (PV port on both sides)

*1 Viewed from the front side of valve unit, confirm the port location on the right and/or left side.

*2 EXH ports are released to atmospheric pressure in both sides. Plugs are always attached to PD ports and all ports of the valve unit.

Thread of supply and exhaust port

Nil	Rc
F	G (Note)
T	NPTF

Note) G thread
The thread ridge shape is compatible with the G thread standard (JIS B 0202), but other shapes are not conforming to ISO16030 and ISO1179.

(Ordering example)

ZZX106-R.....1 pc. (Manifold base)

*ZX1101-K15LZ-EC(-Q).....5 pcs. (Vacuum single unit)

*ZX1-BM1-....1 pc. (Blank plate)

⚠ Caution when ordering manifold

The asterisk denotes the symbol for assembly.
Prefix it to the ejector part numbers to be mounted. When it is not added, the manifold base and ejector are shipped separately.

<Individual spacer>

Use the individual spacer when separating the supply and pilot pressure exhaust ports of the manifold ejector.

ZX1 - R1 - 1

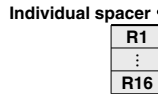

*Refer to the individual spacer.

(Ordering example)

If installed on station 1 and station 3:

ZZX106-R1 pc.

*ZX1101-K15LZ-EL(-Q)

.....6 pcs.

*ZX1-R1-1

*ZX1-R1-3

*ZX1-R16 (Dummy spacer)

.....4 pcs.

Arrangement

(First station from the right end of the valve side is station 1.)

Nil	All stations
1	Station 1 only
⋮	⋮
8	Station 8 only

*When spacers are mounted alternately, specify them together.

*When retrofitting, 3 pcs. of M2.5 x 32 (for ZX) are necessary. A dummy spacer (ZX1-R16) must be mounted on the stations on which individual spacers are not mounted.

About individual spacers

Manifold supply or valve unit supply can be selectable for each port. In the table below, ports with the symbol † mean that they are manifold supply, while others are individual supply from the valve unit.

Symbols in the table below are printed on the surface of individual spacers.

No.	Symbol	No.	Symbol
ZX1-R1	R1	ZX1-R 9	R 9 †PV
R2	R2 †PE	R10	R10 †PV †PE
R3	R3 †PD	R11	R11 †PV †PD
R4	R4 †PD †PE	R12	R12 †PV †PD †PE
R5	R5 †PS	R13	R13 †PV †PS
R6	R6 †PS †PE	R14	R14 †PV †PS †PE
R7	R7 †PS †PD	R15	R15 †PV †PS †PD
R8	R8 †PS †PD †PE	R16	R16 †PV †PS †PD †PE

Manifold/System Circuit Example

When not using individual spacer

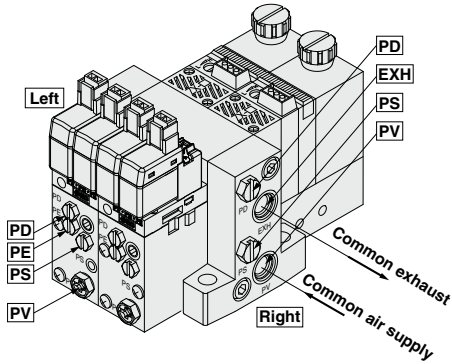

PV: Air pressure SUP port
 PS: Pilot pressure SUP port
 PD: Release pressure SUP port
 PE: Pilot pressure EXH port
 EXH: Common EXH port

When using individual spacer
 (When using ZX1-R1)

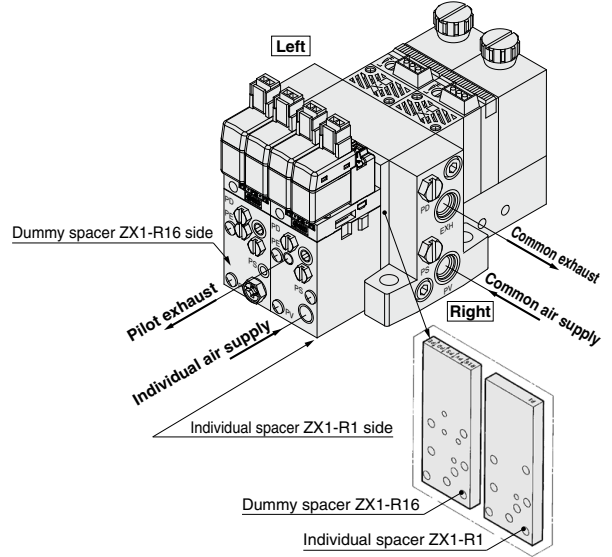

<System circuit example>

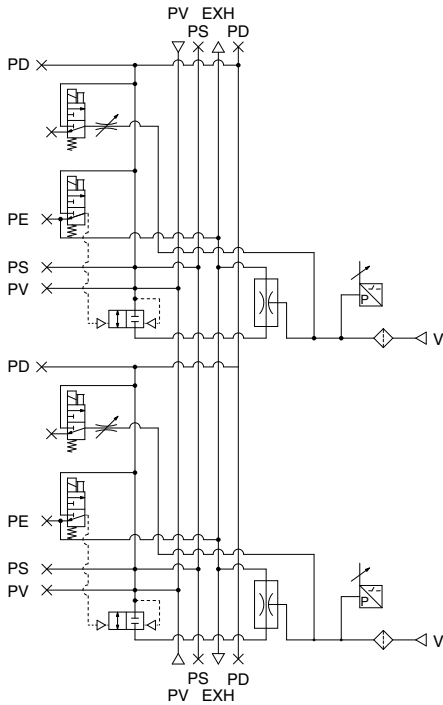

<System circuit example>

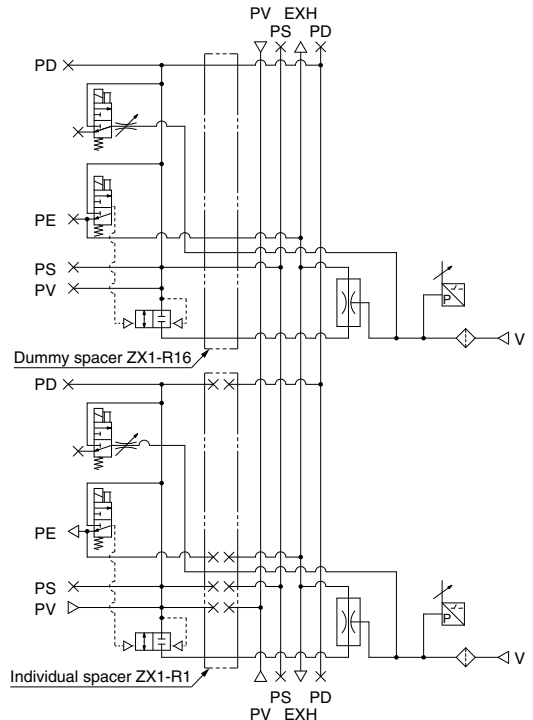

ZA
ZX
ZR
ZM
ZMA
ZQ
ZH
ZU
ZL
ZY□
ZF□
ZP□
SP
ZCUK
AMJ
AMV
AEP
HEP

Related Equipment

(In the case of individual spacer)

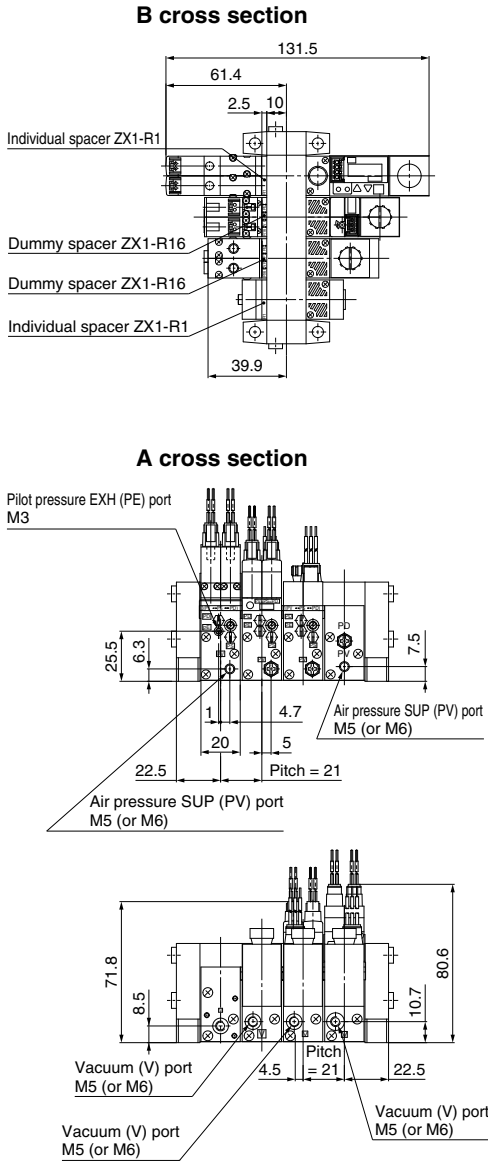

System circuit example

(Standard)

(Semi-standard)
(In the case of individual spacer)

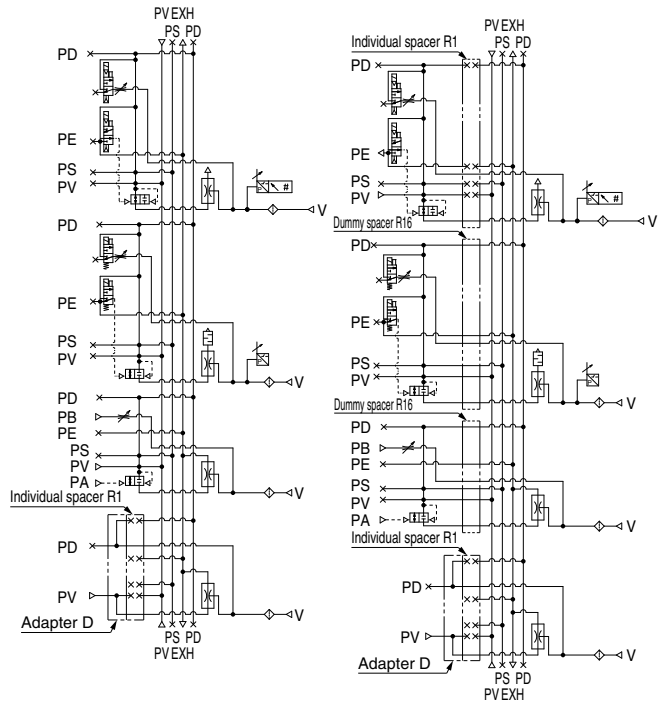

ZA

ZX

ZR

ZM

ZMA

ZQ

ZH

ZU

ZL

ZY □

ZF □

ZP □

SP

ZCUK

AMJ

AMV

AEP

HEP

Related
Equipment

Series ZX

Ejector System

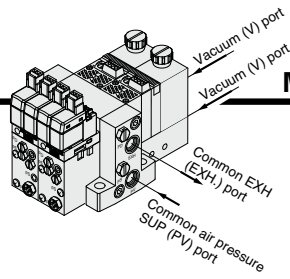

Manifold: Type K1

A: Release flow rate adjusting needle with lock nut

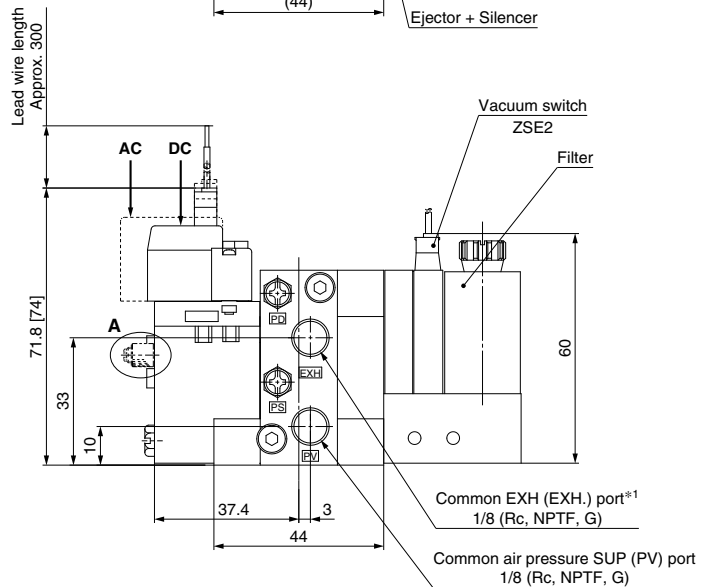
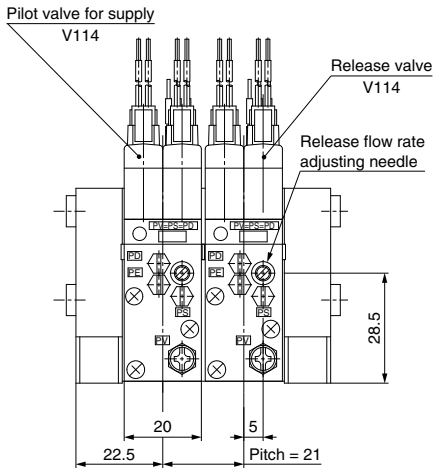
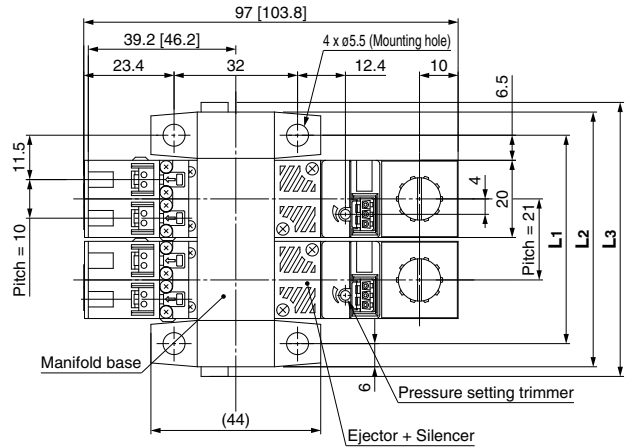
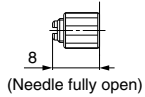

*1 The common exhaust port (EXH.) is also used as the pilot pressure exhaust (PE) port of pilot valve. Use while the port is open to the atmosphere.

		(mm)							
Symbol	Stations	1	2	3	4	5	6	7	8
L1		33	54	75	96	117	138	159	180
L2		45	66	87	108	129	150	171	192
L3		50	71	92	113	134	155	176	197

[]: AC

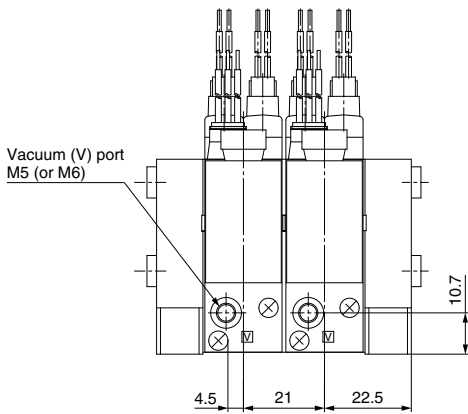

Circuit diagram

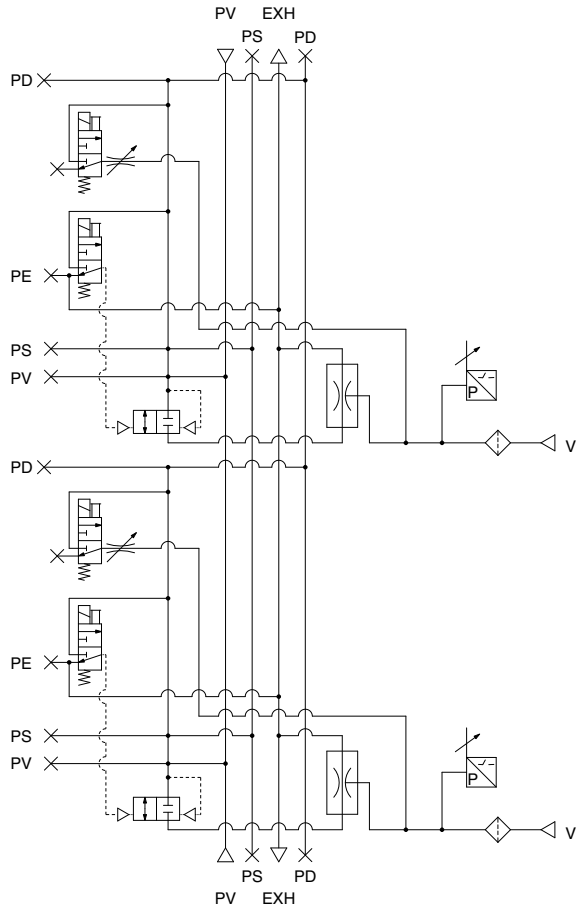

ZA
ZX
ZR
ZM
ZMA
ZQ
ZH
ZU
ZL
ZY□
ZF□
ZP□
SP
ZCUK
AMJ
AMV
AEP
HEP
Related Equipment

Series ZX

Ejector System

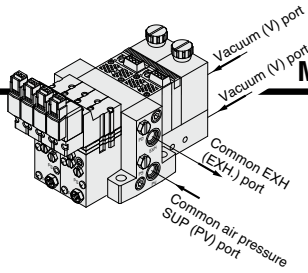

Manifold: Type K3

A: Release flow rate adjusting needle with lock nut

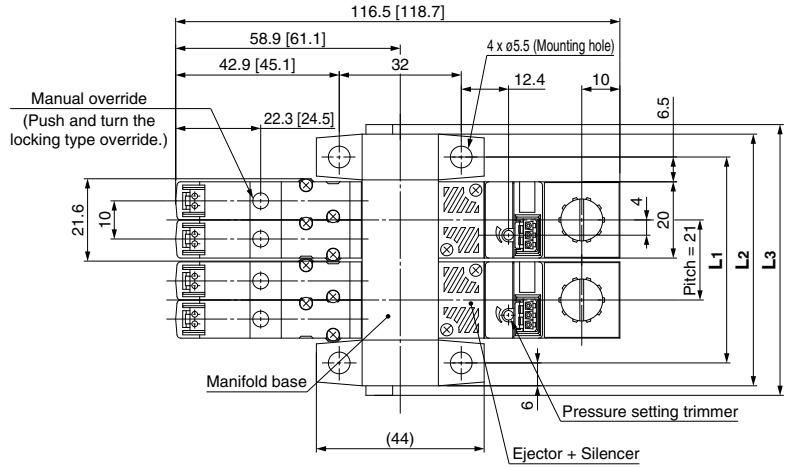
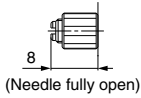

Pilot valve for supply
(Normally open)
SYJ324M

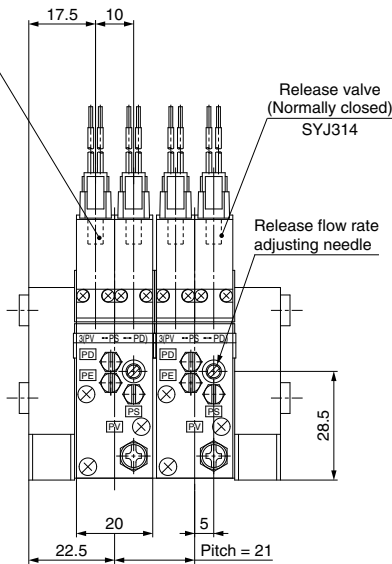

Lead wire length
Approx. 300

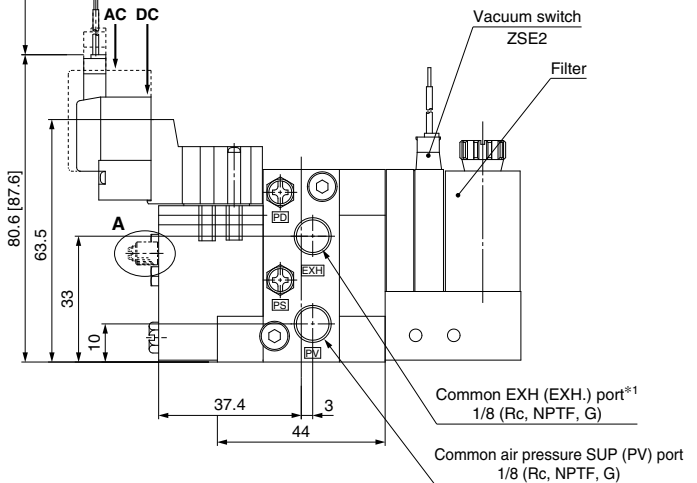

*1 The common exhaust port (EXH.) is also used as the pilot pressure exhaust (PE) port of pilot valve. Use while the port is open to the atmosphere.

		(mm)							
Symbol	Stations	1	2	3	4	5	6	7	8
L1		33	54	75	96	117	138	159	180
L2		45	66	87	108	129	150	171	192
L3		50	71	92	113	134	155	176	197

Circuit diagram

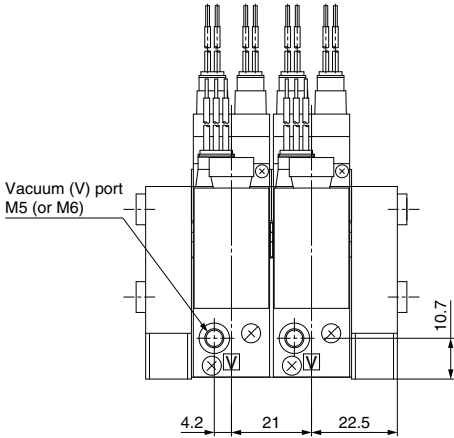
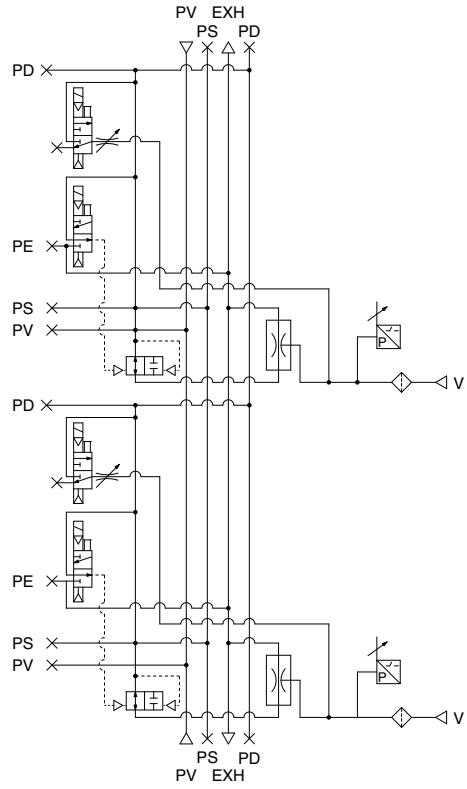

ZA
ZX
ZR
ZM
ZMA
ZQ
ZH
ZU
ZL
ZY □
ZF □
ZP □
SP
ZCUK
AMJ
AMV
AEP
HEP
Related Equipment

Vacuum Module: Vacuum Pump System Series ZX

Note) Refer to "How to Order"
for CE-compliant products. [Option]



How to Order

Components

Valve unit N.C. type	Vacuum switch unit	ZX100	K1	5	L	Z		E	C				
Valve unit N.O. type	Vacuum switch unit	ZX100	K3	5	L	Z		E	C				
Valve unit N.C. type	Filter unit	ZX100	K1	5	L	Z				F			

Valve unit/Combination of supply valve and release valve
Refer to "Table (1)" on page 903.

Solenoid valve rated voltage

		CE-compliant
1* Note)	100 VAC 50/60 Hz	—
3* Note)	110 VAC 50/60 Hz	—
5	24 VDC	●
6	12 VDC	●
V	6 VDC	●
S	5 VDC	●
R	3 VDC	●
Nil	Air operated (K6, K8, J3, J4, D3, D4)	—

Note) CE-compliant products are not available for "1" and "3".

* Applicable to plug connector only. When replacing a product that uses a connector assembly with rectifier, replace the connector assembly as well. (Table (2) on page 903)

Electrical entry

L	L plug connector	Lead wire length 0.3 m
LN	connector	Without lead wire (Applicable to DC only)
LO	type	Without connector
M	M plug connector	Lead wire length 0.3 m
MN	connector	Without lead wire (Applicable to DC only)
MO	type	Without connector
G	Grommet	Lead wire length 0.3 m (Applicable to DC only)
H	type	Lead wire length 0.6 m (Applicable to DC only)
Nil		Air operated

Note) In the case of "K1" (combination of supply and release valves), M type plug connector can not be used.

⚠ Caution

<For DC> Grommet, L and M Plug Connector

With surge voltage suppressor With light/surge voltage suppressor

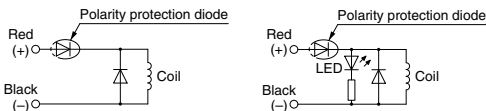

Match the polarity of the connectors according to the ⊕ and ⊖ marks on the connectors. Do not interchange the polarities to prevent the diodes or the switching elements from becoming burned.

If lead wires are pre-connected, the red wire is ⊕ and the black wire is ⊖.

<For AC> L and M Plug Connector

With light (□Z)

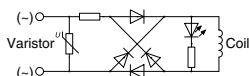

Combination of supply valve and release valve
Solenoid valve rated voltage
Electrical entry
Light/Surge voltage suppressor
Manual operation
Vacuum switch unit
Filter unit
Vacuum switch
Electrical entry
PV, V port size
Release flow rate adjusting needle/Bracket A

CE-compliant

Nil	—
Q	CE-compliant *

* Only for the model with solenoid valve or pressure switch

Release flow rate adjusting needle/Bracket A

	Lock nut	Bracket A
Nil	×	●
L	●	●
M	●	×
N	×	×

PV/V port size

	M5 x 0.8
Nil	—
Y	(Semi-standard)

* When the units are shipped as a manifold, the PV port is M5 x 0.8 with a plug.

●: Attached (Bracket A is shipped together.) ×: None
Note) A bracket is applicable only when the product is to be shipped on its own. When a manifold is to be shipped, a bracket is not included with any of the models.

Vacuum switch electrical entry

Nil	Grommet	Lead wire length 0.6 m
L	type	Lead wire length 3 m
C		Lead wire length 0.6 m
CL	Connector	Lead wire length 3 m
CN	type	Without lead wire assembly with connector

* Refer to "Table (3)" on page 903 for part number of lead wire with connector.

Vacuum switch unit/Filter unit

		CE-compliant
E	Vacuum switch (For general purpose)(ZSE2)(NPN)	With suction filter ●
E55	Vacuum switch (For general purpose)(ZSE2)(PNP)	filter ●
F	Only suction filter	—

Vacuum digital pressure switch unit (ZSE3)

21		2 outputs/without analog output
22		2 outputs/with analog output
23	1 output (with trouble detection)/without analog output	
24	1 output (with trouble detection)/with analog output	

Note) Analog output is available only on grommet type.

Manual operation

Nil	Non-locking push type
B	Locking slotted type

The filter mounted on the product is a simplified one. When used in an environment with a lot of dust, the filter is likely to be clogged quickly. The use with the series ZFA, ZFB and ZFC is recommended.

Light/Surge voltage suppressor

Nil	None
Z	With light/surge voltage suppressor
S*	With surge voltage suppressor

S is not available for AC.

If the polarity is incorrect at DC voltage (surge voltage suppressor), diode or switching element may be damaged.

- Refer to "Table (2)" on page 903 for part number of lead wire with connector.
- Refer to page 916 for ordering the manifold.
- Refer to pages 926 and 927 for ordering a unit for replacement.

Table (1) Valve Unit/Combination of Supply Valve and Release Valve

(Refer to page 904 for detailed specifications.)

Components		Symbol	Supply valve					Release valve					Weight (g)
Supply valve	Release valve		Solenoid valve		Air operated		None	Solenoid valve		Air operated	External release	None	
			N.C. (V114)	N.O. (SYJ324)	N.C. (ZX1A)	N.O. (SYJA324)		N.C. (V114)	N.C. (SYJ314)	N.C. (SYJA314)	ZX1A		
Solenoid (N.C.)	Solenoid (N.C.)	K1	●	—	—	—	—	●	—	—	—	—	79
Solenoid (N.O.)	Solenoid (N.C.)	K3	—	●	—	—	—	—	●	—	—	—	112
Air operated (N.C.)	External release	K6	—	—	●	—	—	—	—	—	●	—	53
Air operated (N.O.)	Air operated (N.C.)	K8	—	—	—	●	—	—	—	●	—	—	83
—		Nil	Without valve module										

Table (2) Valve Unit/Valve Plug Connector Assembly

For DC:

SY100-30-4A - 

For 100 VAC:

SY100-30-1A - 

For 110 VAC:

SY100-30-3A - 

Without lead wire:

(with connector and 2 sockets only)

SY100-30-A

Lead wire length

Nil	0.3 m
6	0.6 m
10	1 m
15	1.5 m
20	2 m
25	2.5 m
30	3 m
50	5 m

How to order

If ordering vacuum module with 600 mm or the longer lead wire, specify both vacuum module and connector assembly part numbers.

(Ordering example)

ZX100-K15LOZ-EC(-Q) 1 pc.

*SY100-30-4A-6 2 pcs.

↳ The asterisk (*) denotes the symbol for assembly.

Warning

When replacing a product that uses a connector assembly with rectifier, replace the connector assembly as well.

Table (3) Vacuum Switch/Plug Connector Assembly

For ZSE2 **ZS-10-5A** - 

For ZSE3 **ZS-20-5A** - 

Lead wire length

Nil	0.6 m
30	3 m
50	5 m

Note) If ordering switch with 5 m lead wire, specify both switch and lead wire connector part numbers.

Ordering example)

ZX100-K150Z-ECN(-Q) 1 pc.

*SY100-30-4A-6 2 pcs.

*ZS-10-5A-50 1 pc.

↳ The asterisk (*) denotes the symbol for assembly.

Ejector System/Recommended Model (The models below are for express delivery.)

Model	Combination		Solenoid valve rated voltage	Lead wire electrical entry	Light/Surge voltage suppressor	Vacuum switch unit /Filter unit	Vacuum switch electrical entry
	Supply valve (Pilot valve)	Release valve (Direct operated)					
ZX100-K15LZ-F	N.C. (V114)	N.C. (V114)	24 VDC	Plug connector type	With light/surge voltage suppressor	Suction filter (ZX1-F)	Connector type
ZX100-K15LZ-EC	N.C. (V114)	N.C. (V114)					
ZX100-K35MZ-EC	N.O. (SYJ324M)	N.C. (SYJ314)					

*The above models are for express delivery.

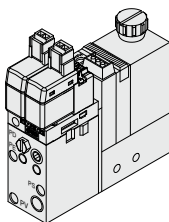

ZX100-K15LZ-E □

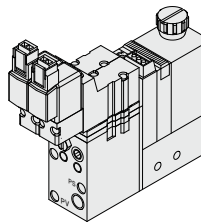

ZX100-K35MZ-E □

ZA

ZX

ZR

ZM

ZMA

ZQ

ZH

ZU

ZL

ZY □

ZF □

ZP □

SP

ZCUK

AMJ

AMV

AEP

HEP

Related Equipment

Vacuum Pump System/Combination of Supply Valve and Release Valve

Combination Symbol: **K1**

Application: This combination is used for effecting control in accordance with electric signals.

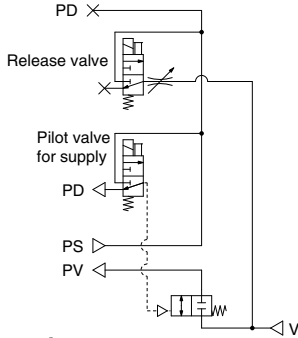

How to Operate

Condition	Valve	
	Supply valve Solenoid valve	Release valve Solenoid valve
1. Work adsorption	ON	OFF
2. Vacuum release	OFF	ON
3. Operation stop	OFF	OFF

Combination Symbol: **K6**

Application: This combination is used for effecting control in accordance with air signals.

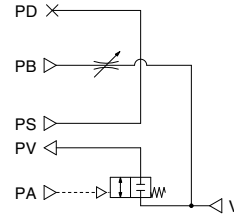

How to Operate

Condition	Valve	
	Supply valve External 3 port valve	Release valve External 2 port valve
1. Work adsorption	ON	OFF
2. Vacuum release	OFF	ON
3. Operation stop	OFF	OFF

Combination Symbol: **K3**

Application: This combination is used for effecting control in accordance with electric signals. Because the supply valve is N.O., the pressure that is supplied to the ejector is not interrupted during a power outage; as a result, the state of suction can be maintained. This combination is used for preventing the workpieces from dropping during power outages.

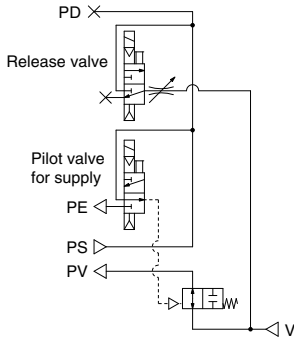

How to Operate

Condition	Valve	
	Supply valve Solenoid valve	Release valve Solenoid valve
1. Work adsorption	OFF	OFF
2. Vacuum release	ON	ON
3. Operation stop	ON	OFF

Combination Symbol: **K8**

Application: This combination is used for effecting control in accordance with air signals. Because the supply valve is N.O., the pressure that is supplied to the ejector is not interrupted during a power outage; as a result, the state of suction can be maintained. This type is used for preventing the workpieces from dropping during power outages.

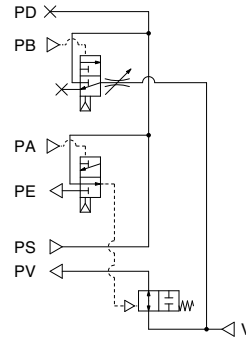

How to Operate

Condition	Valve	
	Supply valve Air operated valve	Release valve Air operated valve
1. Work adsorption	OFF	OFF
2. Vacuum release	ON	ON
3. Operation stop	ON	OFF

Vacuum Pump System/Construction

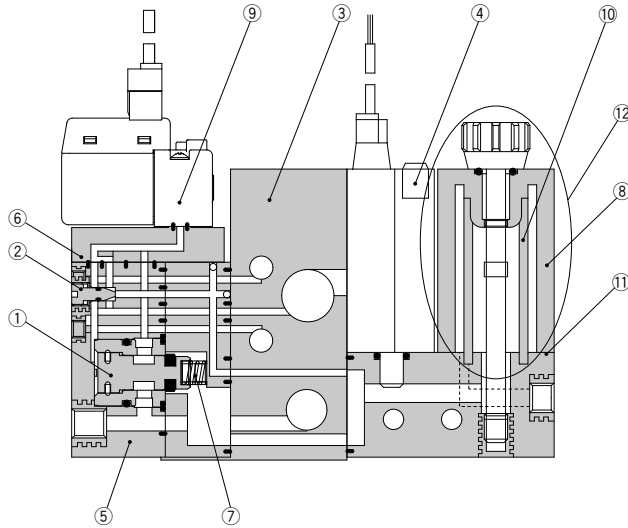

Component Parts

No.	Description	Material	Note
1	Poppet valve assembly	—	ZX1-PV-0
2	Release flow rate adjusting needle	Stainless steel	ZX1-NA
3	Manifold base	Aluminum	
4	Vacuum switch	—	ZSE2, ZSE3
5	Valve unit	—	ZX1-VB □□□□□□-D-□
6	Interface plate	—	(PV)/(PS↔PD)
7	Return spring	Stainless steel	
8 ^{Note)}	Filter case	Polycarbonate	

Replacement Parts

No.	Description	Material	Part no.
9	Pilot valve	—	Refer to "Table (2)", "(3)".
10	Filter element	PVA	ZX1-FE
11	Gasket	—	ZX1-FG
12	Filter case assembly	—	ZX1-FK-PC*

* Component parts
Filter case, filter element, tension bolt (including O-rings)
(Gasket ⑪ is not included.)

Note) Caution when handling filter case

- The case is made of polycarbonate. Therefore, do not use it with or expose it to the following chemicals: paint thinner, carbon tetrachloride, chloroform, acetic ester, aniline, cyclohexane, trichloroethylene, sulfuric acid, lactic acid, watersoluble cutting oil (alkalinic), etc.
- Do not expose it to direct sunlight.

Table (1) How to Order Pilot Valves

No.	Component equipment		Model	Combination of supply and release valve
	Supply valve	Release valve		
1	Solenoid valve N.C. (V114)	Solenoid valve N.C. (V114)	Z1-V114-□□□□	K1
2	Solenoid valve N.O. (SYJ324M)	Solenoid valve N.C. (SYJ314)	ZX1-SYJ3 ¹ / ₂ 4□-□□□□	K3
3	Air operated N.O. (SYJA324)	Air operated N.C. (SYJA314)	ZX1-SYJA3 ¹ / ₂ 4	K6
4	Solenoid valve Air operated	Air operated Solenoid valve	No. 2 and 3 models only are applicable. Indicate each part number.	

Table (3) How to Order Air Operated Valves

ZX1A-M5

Port size

M5	M5 x 0.8	Pilot port/ External release port
----	----------	--------------------------------------

⚠ Caution

Turning the vacuum release flow volume adjusting needle clockwise reduces the vacuum release flow volume; the needle valve is fully closed when the needle stops turning. Turning the needle 2 full turns counterclockwise from the fully closed position renders the needle valve fully open. The needle will fall out if it is turned more than 4 full turns. In order to prevent the needle from loosening and falling out, the release flow rate adjusting needle with lock nut (ZX1-ND-L) is also available.

Table (2) How to Order Solenoid Valves

●Supply valve (N.C.): K1, J1

Z1 - V114 - 5 L Z □

●Supply valve (N.O.): K3, J2

Supply valve (N.O.)
ZX1 - SYJ324M - 5 L Z □

Release valve (N.C.)
ZX1 - SYJ314 - 5 L Z □

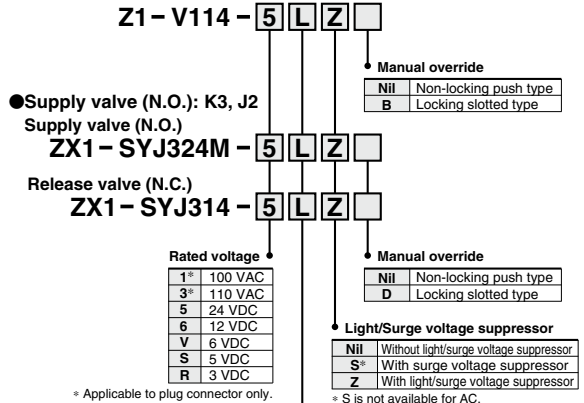

* Applicable to plug connector only.

* S is not available for AC.

Electrical entry

L	Connector (0.3 m)
LN	Connector (without lead wire)
LO	Without connector
M*	Connector (0.3 m)
MN*	Connector (without lead wire)
MO*	Without connector
G	Grommet (0.3 m)
H	Grommet (0.6 m)

* In the case of Z1-V114, M, MN and MO cannot be selected.

- ZA
- ZX**
- ZR
- ZM
- ZMA
- ZQ
- ZH
- ZU
- ZL
- ZY□
- ZF□
- ZP□
- SP
- ZCUK
- AMJ
- AMV
- AEP
- HEP

Related Equipment

Valve Unit: ZX1-VB

Refer to page 872 for details.

Model/Specifications

Unit no.	ZX1-VB□□□□□□					
Components	Supply valve			Release valve		
	Pilot type			Direct operated type		
Operation	Solenoid valve		Air operated		Solenoid valve	External release
	N.C. (V114)	N.O. (SYJ324)	N.C. (ZX1A)	N.O. (SYJA324)	N.C. (V114)	N.C. (SYJ314)
Cv factor	0.17			0.008	0.08	—
Supply pressure range of vacuum pressure SUP (PV) port	-0.1 to 0 MPa					
Supply pressure range of pilot pressure SUP (PS) port	0.3 to 0.6 MPa					
Supply pressure range of pilot pressure SUP (PA, PB) ports for supply and release ^{Note)}	PS port pressure to 0.6 MPa					
Max. operating frequency	5 Hz					
Operating temperature range	5 to 50°C					
Interface plate symbol	(PV)•(PS↔PD)					
Standard accessory	Bracket B (ZX1-OBB)					

Note) The supply and release valves of this product have a structure which uses the pressure of the pilot pressure SUP (PS) port to operate them. Be sure to supply a pressure that is the pressure of the pilot pressure SUP (PS) port or more and 0.6 MPa or less to the pilot pressure SUP (PA, PB) ports for supply and release.

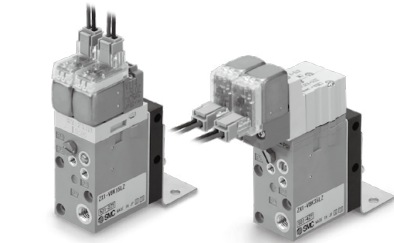

K1 (Normally closed)

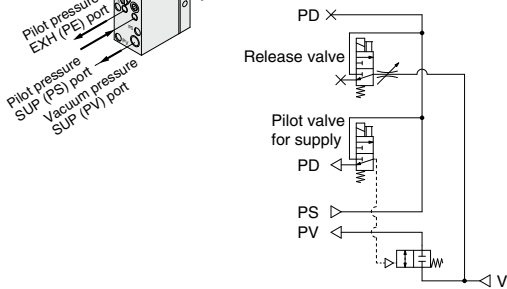

K3 (Normally open)

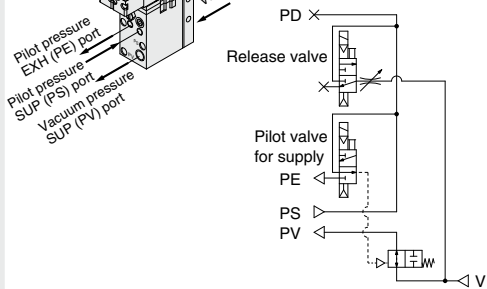

A: Release flow rate adjusting needle with lock nut

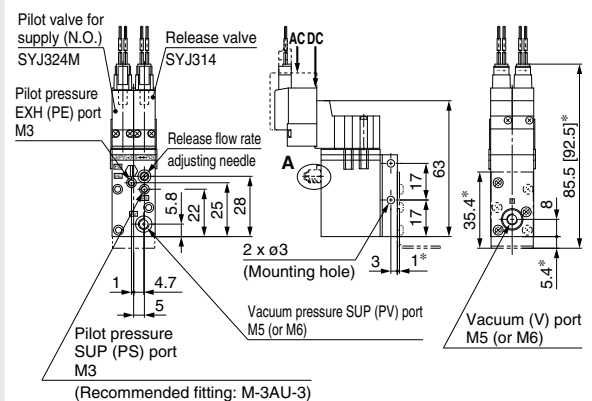
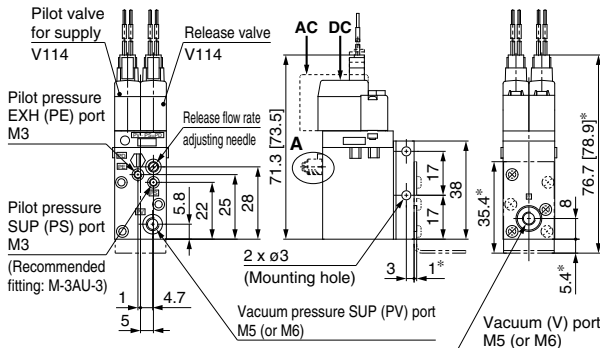
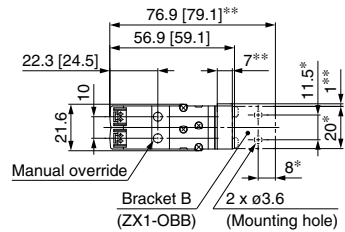
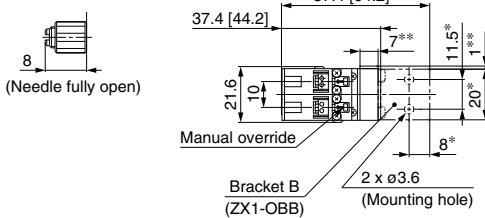

Note) Dimensions *: For mounting bracket B **: For mounting spacer

[]: AC

Suction Filter Unit: ZX1-F

Refer to page 874 for details.

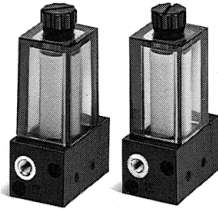

Specifications

Unit no.		ZX1-F
Operating pressure range		-100 to 500 kPa
Operating temperature range		5 to 50°C
Filtration efficiency		30 μm
Filter media		PVA
Weight	37 g	ZX1-F-□ (With bracket A)
	29 g	ZX1-F-□-N (Without bracket A)

Note) If not operated within the specified range of pressure and temperature, trouble may be caused.

How to Order

ZX1 - F - □ - □

PV, V port size

Nil	M5 x 0.8
Y	M6 x 1 (Semi-standard)

Bracket

Nil	With bracket A
N	Without bracket A

Vacuum Pressure Switch Unit/ZSE2, ZSE3

Refer to pages 875 to 880 for details.

Vacuum Pressure Switch

High speed response/10 ms
Uses a carrier diffusion
semiconductor pressure
sensor



Vacuum Pressure Switch Specifications

Refer to Best Pneumatics No. 6 for details.

Unit no.	ZSE2-0X	ZSE3-0X
Fluid	Air	
Set pressure range	0 to -101 kPa	
Hysteresis	3% Full span or less	
Repeatability	±1% Full span or less	
Temperature characteristics	±3% Full span or less	
Voltage	12 to 24 VDC (Ripple ±10% or less)	
Port size	M5 x 0.8, M6 x 1 (Semi-standard)	

Note) If not operated within the specified range of pressure and temperature, trouble may be caused.

• Filter case

⚠ Caution

- The case is made of polycarbonate. Therefore, do not use it with or expose it to the following chemicals: paint thinner, carbon tetrachloride, chloroform, acetic ester, aniline, cyclohexane, trichloroethylene, sulfuric acid, lactic acid, water-soluble cutting oil (alkalinic), etc.
- Do not expose it to direct sunlight.

ZA

ZX

ZR

ZM

ZMA

ZQ

ZH

ZU

ZL

ZY□

ZF□

ZP□

SP

ZCUK

AMJ

AMV

AEP

HEP

Related
Equipment

Series ZX

Valve Unit: Type K1

Configuration and combination

	Vacuum switch (ZSE2)
Valve unit (K1) +	Vacuum switch (ZSE3)
	Filter unit (F)

Model
ZX100 — **K1**□□□□ — **D**□□□
F

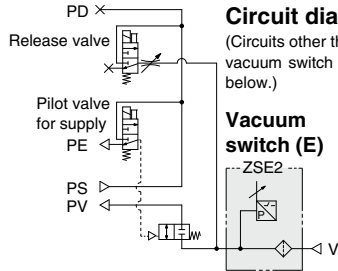
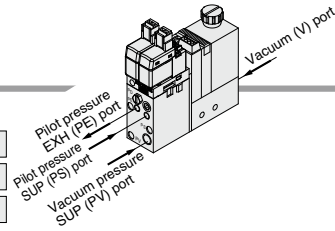

Circuit diagram

(Circuits other than those with vacuum switch are shown as below.)

Vacuum switch (E)

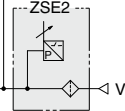

Vacuum digital pressure switch (D)

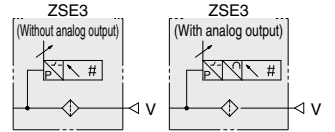

Filter unit

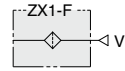

Vacuum switch (ZSE2)

ZX100-K1□□□□-E□

A: Release flow rate adjusting needle with lock nut

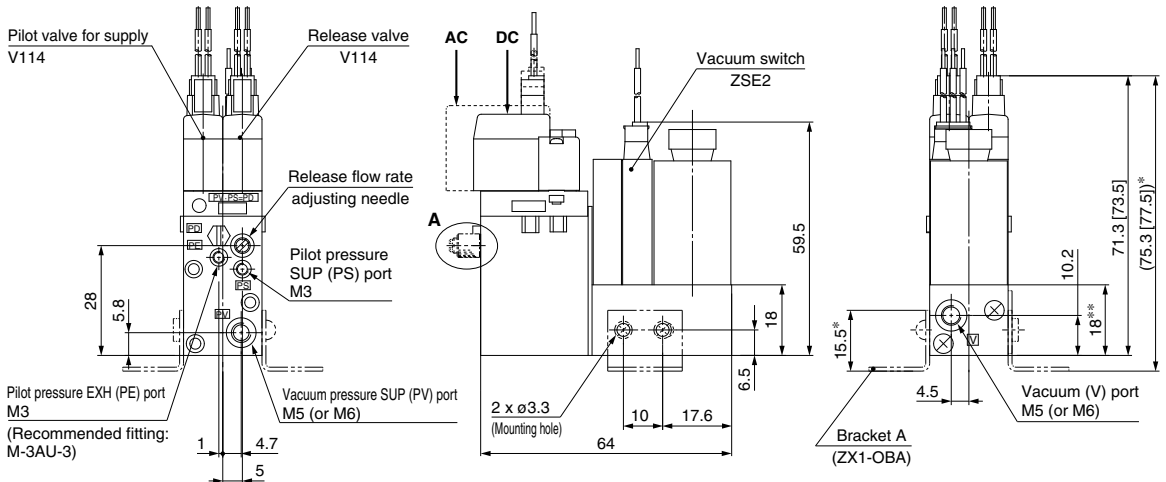
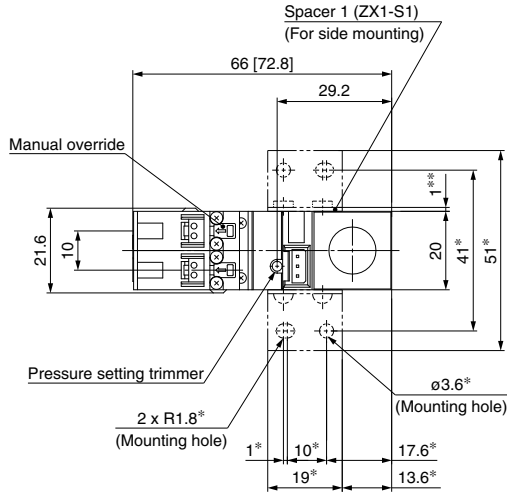
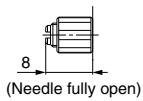

Note) Dimensions *: For mounting bracket A **: For mounting spacer 1.

[]: AC

Filter unit (F)
ZX100-K3□□□□-F

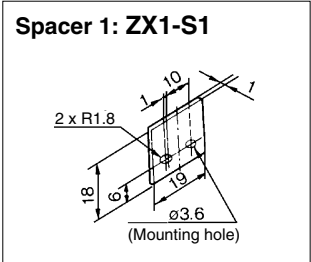
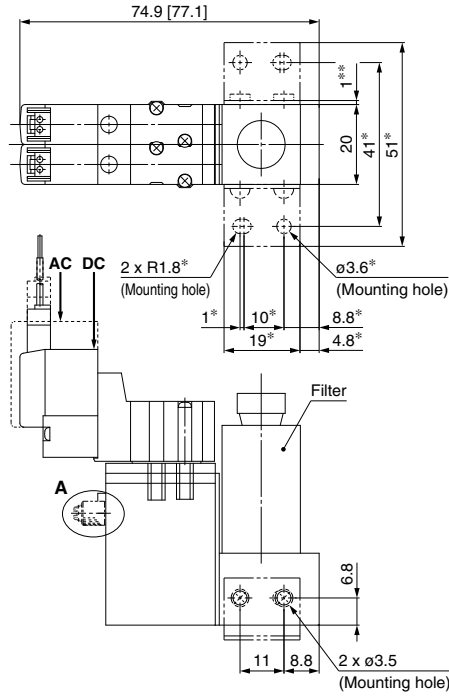

- ZA
- ZX**
- ZR
- ZM
- ZMA
- ZQ
- ZH
- ZU
- ZL
- ZY□
- ZF□
- ZP□
- SP
- ZCUK
- AMJ
- AMV
- AEP
- HEP

Related
Equipment

Filter unit (F)
ZX100-K6-F

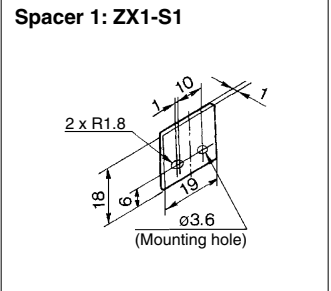
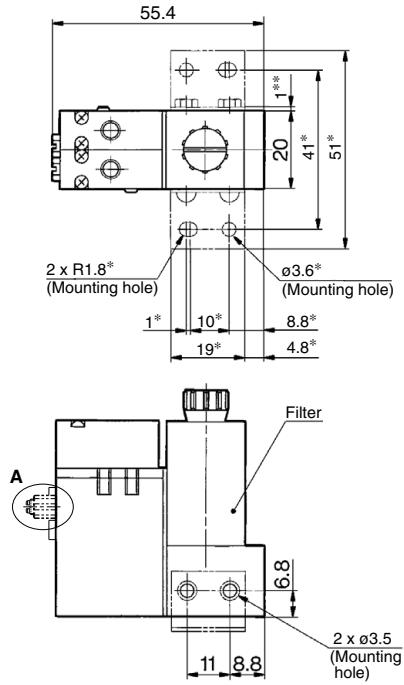

ZA
ZX
ZR
ZM
ZMA
ZQ
ZH
ZU
ZL
ZY □
ZF □
ZP □
SP
ZCUK
AMJ
AMV
AEP
HEP
Related Equipment

Series ZX

Valve Unit: Type K8

Configuration and combination

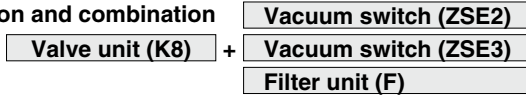

Model **E**
ZX100 — **K8** — **F**
 D

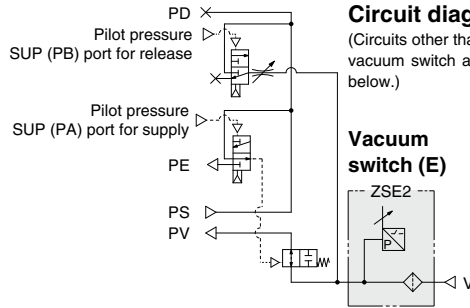
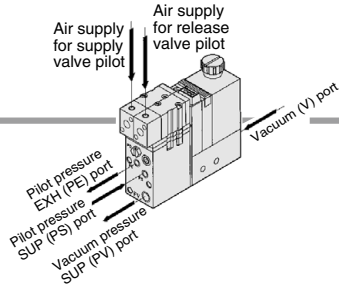

Circuit diagram

(Circuits other than those with vacuum switch are shown as below.)

Vacuum switch (E)

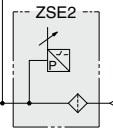

Vacuum digital pressure switch (D)

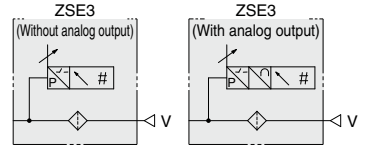

Filter unit

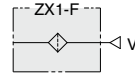

Vacuum switch (ZSE2)

ZX100-K8-E

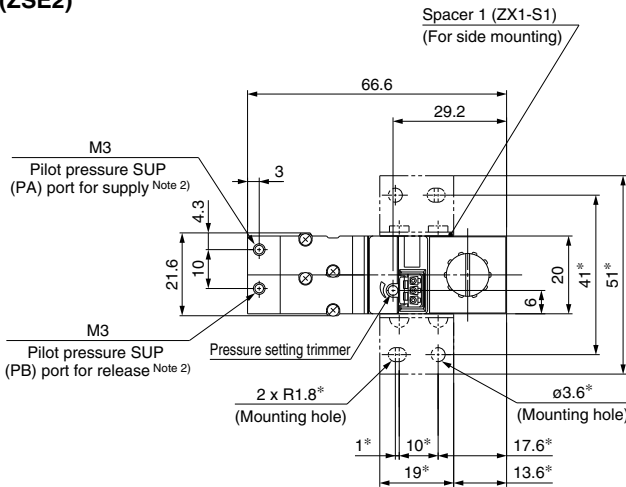

A: Release flow rate adjusting needle with lock nut

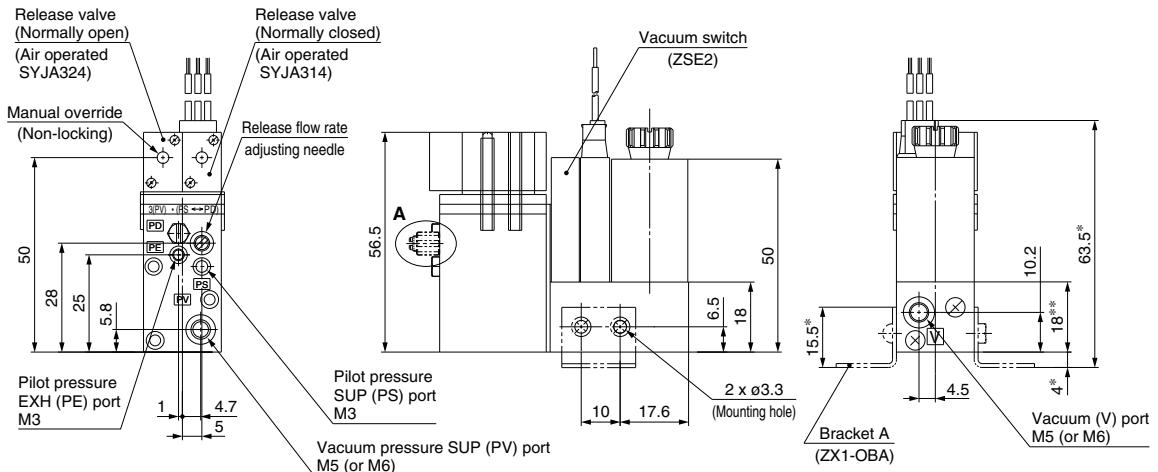
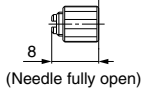

Note 1) Dimensions *: For mounting bracket A **: For mounting spacer 1.

Note 2) Combination of supply valve and release valve: K4, K7, K8, J4, D4

The supply and release valves of this product have a structure which uses the pressure of the pilot pressure SUP (PS) port to operate them. Be sure to supply a pressure that is the pressure of the pilot pressure SUP (PS) port or more and 0.6 MPa or less to the pilot pressure SUP (PA, PB) ports for supply and release.

Vacuum Pump System/Manifold Specifications

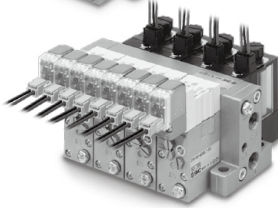
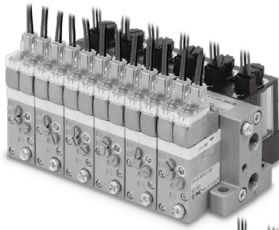

Specifications

Max. number of units		Max. 8 units
Port size	Supply port [PV]	1/8 (Rc, NPTF, G)
	Exhaust port [EXH]	1/8 (Rc, NPTF, G)
Weight		1 station: 110 g (45 g per additional station)

Note 1) PD port: Blank

Note 2) Vacuum from both sides of PV port for 6 or more stations of ZX100 external vacuum pump manifold.

Air Supply

Supply port location	Manifold Port		Left side		Right side	
			PV	PS	PV	PS
L (Left)			○	○	●	●
R (Right)			●	●	○	○
B (Both sides)			○	○	○	○

○ : Vacuum supply from PV port ○ : Air supply from PS port

● : Plugged

Note) All ports for each valve unit are provided with plugs.

How to Order Manifold

<Manifold base>

ZZX1 06 - [] R

Stations

01	1
02	2
⋮	⋮
08	8

Supply port location

Symbol	Supply port location *1	Air Supply	
		Vacuum supply	Air supply
R	Right side	PV port on the right side	PS port on the right side
L	Left side	PV port on the left side	PS port on the left side
B	Both sides	PV port on both sides	PS port on both sides

Thread of supply and exhaust valve

Nil	Rc
F	G (Note)
T	NPTF

Note) G thread

The thread ridge shape is compatible with the G thread standard (JIS B 0202), but other shapes are not conforming to ISO16030 and ISO1179.

- * 1 Viewed from the front side of valve unit, confirm the port location on the right and/or left side.
- * 2 EXH ports are released to atmospheric pressure in both sides. Plugs are always attached to PD ports and all ports of the valve unit.

(Ordering example)

ZZX106-R1 pc. (Manifold base)

*ZX100-K15LZ-EC(-Q)

.....5 pcs. (Vacuum single unit)

*ZX1-BM1

.....1 pc. (Blank plate)

<Individual spacer>

Use the individual spacer when separating the supply and pilot pressure exhaust ports of the manifold ejector.

ZX1 - R1 - 1

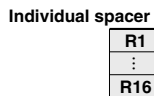

*Refer to the individual spacer.

(Ordering example)
If installed on station 1 and station 3:

ZZX106-R1 pc.

*ZX100-K15LZ-EC(-Q)

.....6 pcs.

*ZX1-R1-1

*ZX1-R1-3

*ZX1-R16 (Dummy spacer)

.....4 pcs.

Arrangement

(First station from the right end of the valve side is station 1.)

Nil	All stations
1	Station 1 only
⋮	⋮
8	Station 8 only

*When spacers are mounted alternately, specify them together.

*When retrofitting, 3 pcs. of M2.5 x 32 (for ZX) are necessary. A dummy spacer (ZX1-R16) must be mounted on the stations on which individual spacers are not mounted.

About individual spacers

- Manifold supply or valve unit supply can be selectable for each port. In the table below, ports with the symbol † mean that they are manifold supply, while others are individual supply from the valve unit.
- Symbols in the table below are printed on the surface of individual spacers.

Part no.	Symbol	Part no.	Symbol
ZX1-R1	R1	ZX1-R 9	R 9 † PV
R2	R2 † PE	R10	R10 † PV † PE
R3	R3 † PD	R11	R11 † PV † PD
R4	R4 † PD † PE	R12	R12 † PV † PD † PE
R5	R5 † PS	R13	R13 † PV † PS
R6	R6 † PS † PE	R14	R14 † PV † PS † PE
R7	R7 † PS † PD	R15	R15 † PV † PS † PD
R8	R8 † PS † PD † PE	R16	R16 † PV † PS † PD † PE

⚠ Caution when ordering manifold

The asterisk denotes the symbol for assembly.

Prefix it to the ejector part numbers to be mounted. When it is not added, the manifold base and ejector are shipped separately.

Manifold/System Circuit Example

When not using individual spacer

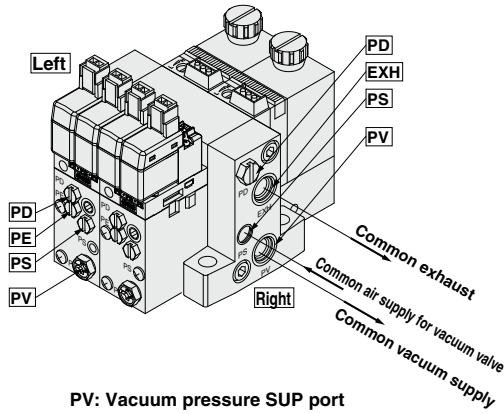

PV: Vacuum pressure SUP port
PS: Pilot pressure SUP port
PD: Release pressure SUP port
PE: Pilot pressure EXH port
EXH: Common EXH port

When using individual spacer
(When using ZX1-R1)

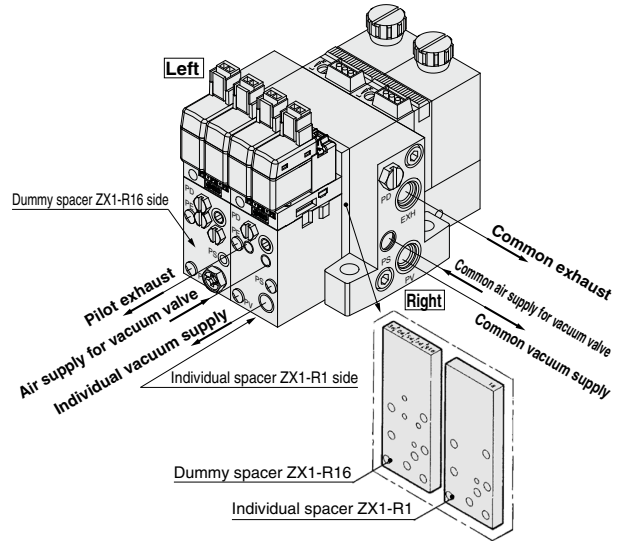

<System circuit example>

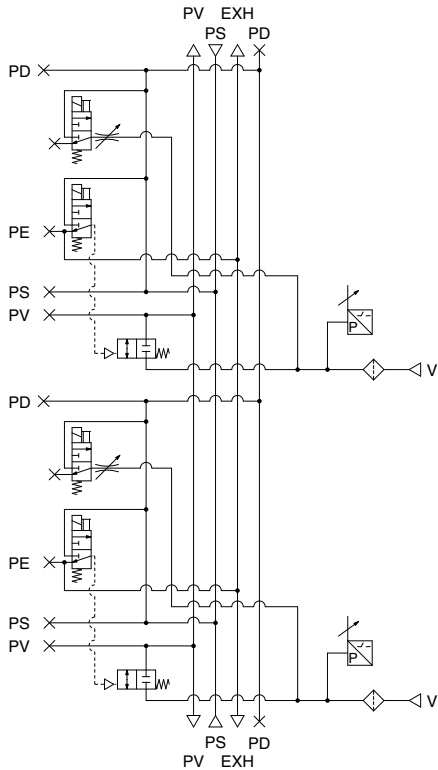

<System circuit example>

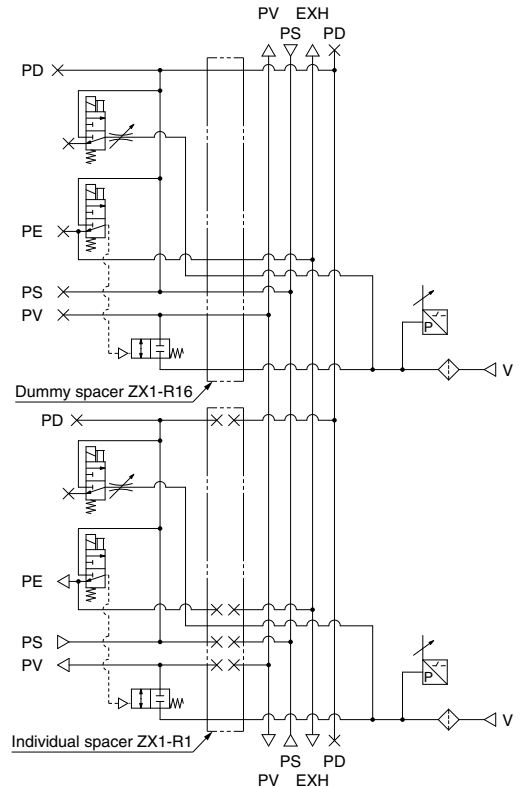

ZA
ZX
ZR
ZM
ZMA
ZQ
ZH
ZU
ZL
ZY□
ZF□
ZP□
SP
ZCUK
AMJ
AMV
AEP
HEP

Related
Equipment

Vacuum Pump System Manifold

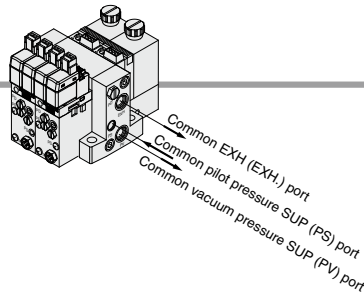

A: Release flow rate adjusting needle with lock nut

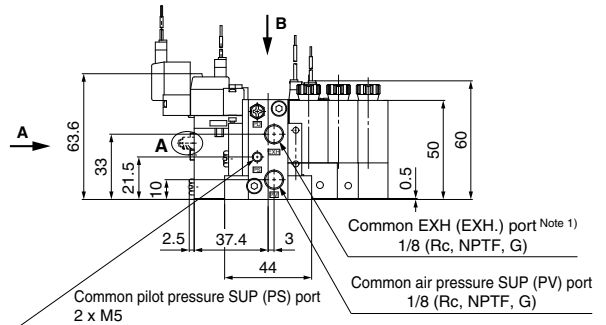
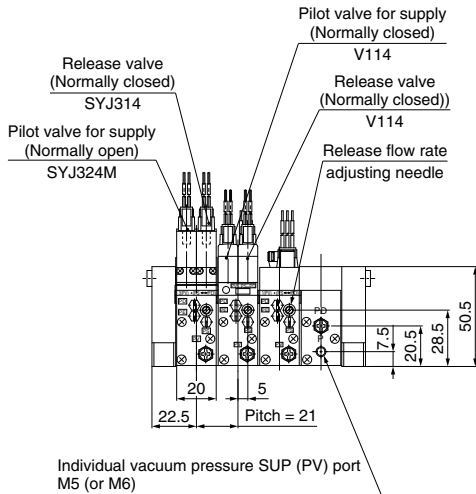
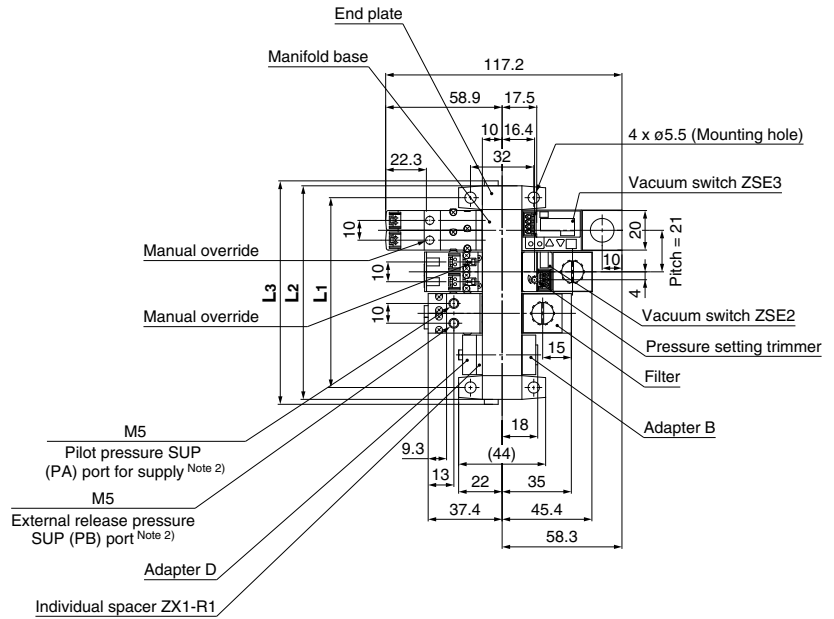
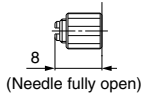

Note 1) The common exhaust port (EXH.) is also used as the pilot pressure exhaust (PE) port of pilot valve. Use while the port is open to the atmosphere.

Note 2) Combination of supply valve and release valve: K4, K5, K6, K7, K8, J3, J4, D4

The supply and release valves of this product have a structure which uses the pressure of the pilot pressure SUP (PS) port to operate them. Be sure to supply a pressure that is the pressure of the pilot pressure SUP (PS) port or more and 0.6 MPa or less to the pilot pressure SUP (PA, PB) ports for supply and release.

		(mm)							
Symbol	Stations	1	2	3	4	5	6	7	8
L1		33	54	75	96	117	138	159	180
L2		45	66	87	108	129	150	171	192
L3		50	71	92	113	134	155	176	197

(In the case of individual spacer)

B cross section

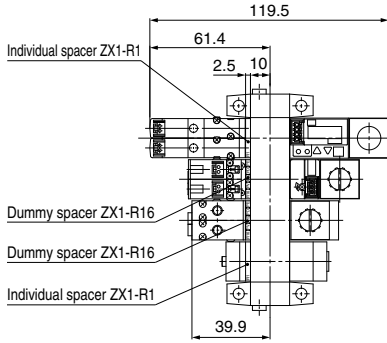

A cross section

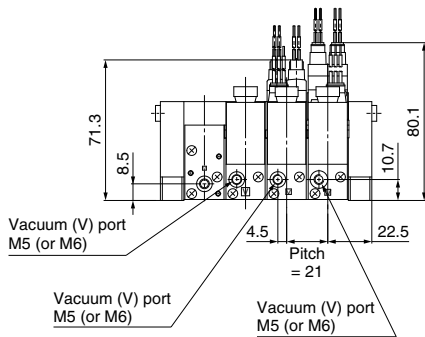
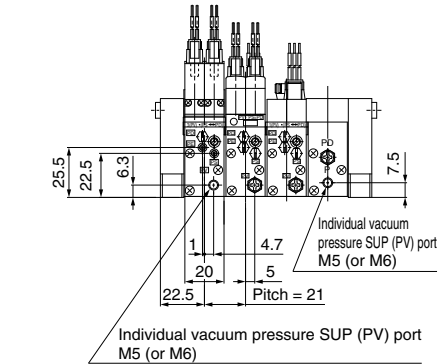

System circuit example

(Standard)

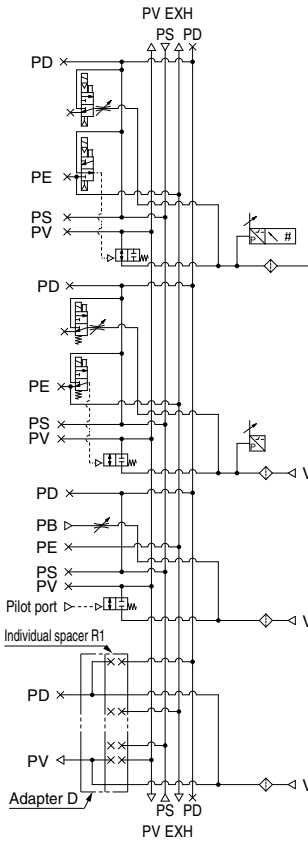

(Semi-standard)
(In the case of individual spacer)

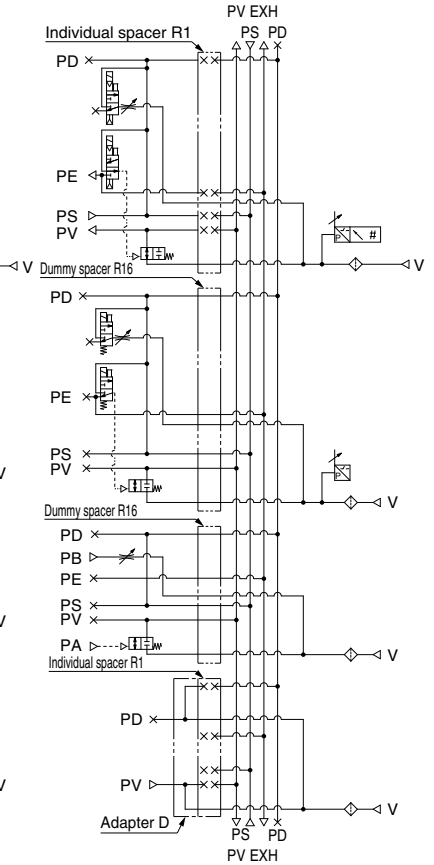

ZA
ZX
ZR
ZM
ZMA
ZQ
ZH
ZU
ZL
ZY□
ZF□
ZP□
SP
ZCUK
AMJ
AMV
AEP
HEP
Related Equipment

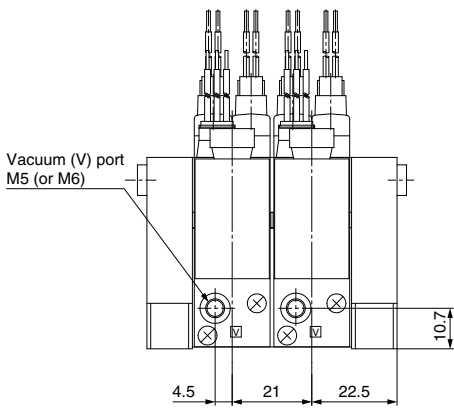

Circuit diagram

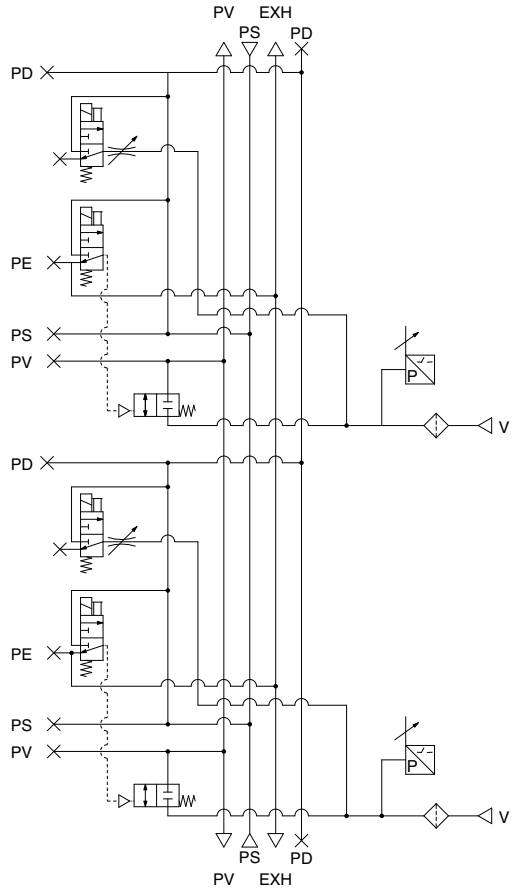

ZA
ZX
ZR
ZM
ZMA
ZQ
ZH
ZU
ZL
ZY□
ZF□
ZP□
SP
ZCUK
AMJ
AMV
AEP
HEP
Related Equipment

Series ZX

Vacuum Pump System Manifold: Type K3

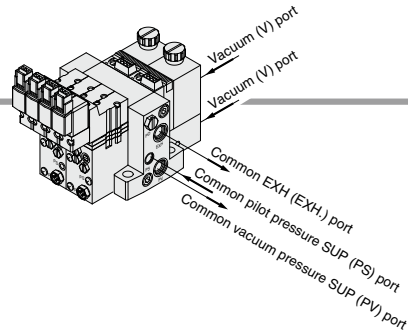

A: Release flow rate adjusting needle with lock nut

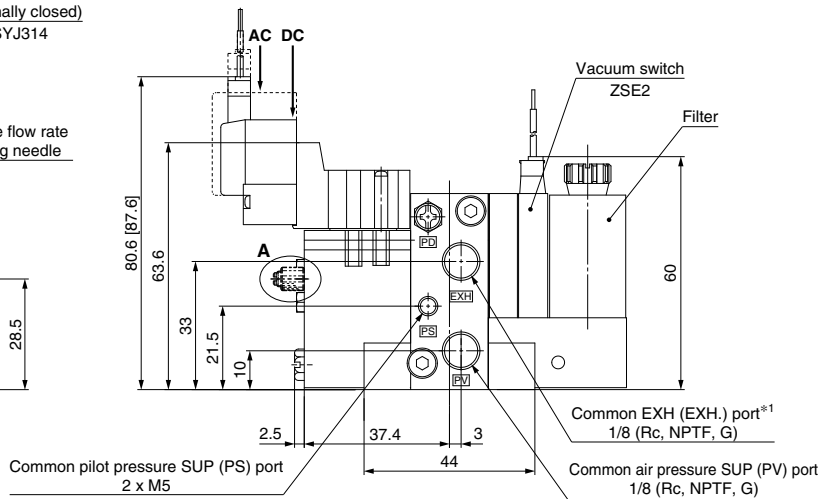
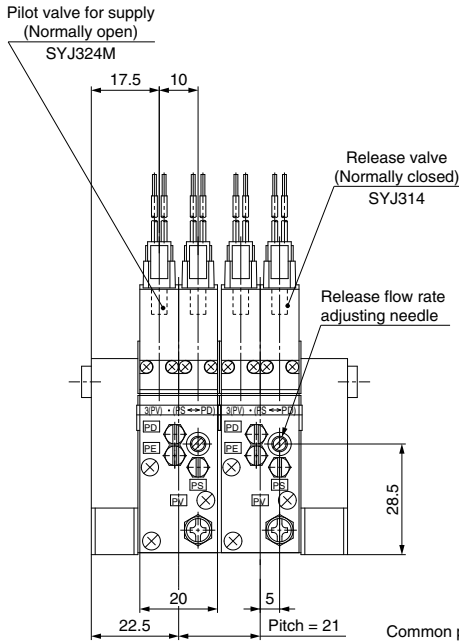
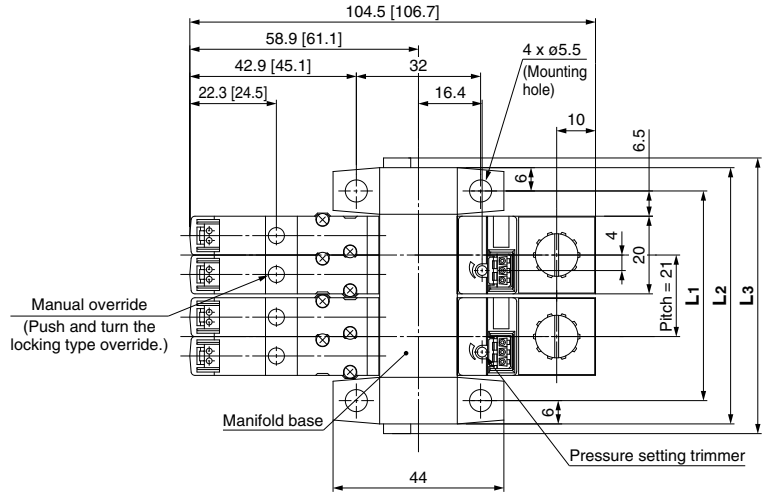
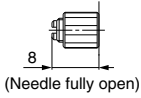

*1 The common exhaust port (EXH.) is also used as the pilot pressure exhaust (PE) port of pilot valve. Use while the port is open to the atmosphere.

[]: AC

		(mm)							
Symbol	Stations	1	2	3	4	5	6	7	8
L1		33	54	75	96	117	138	159	180
L2		45	66	87	108	129	150	171	192
L3		50	71	92	113	134	155	176	197

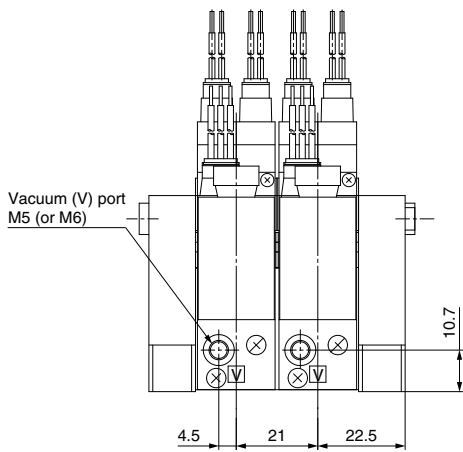

Circuit diagram

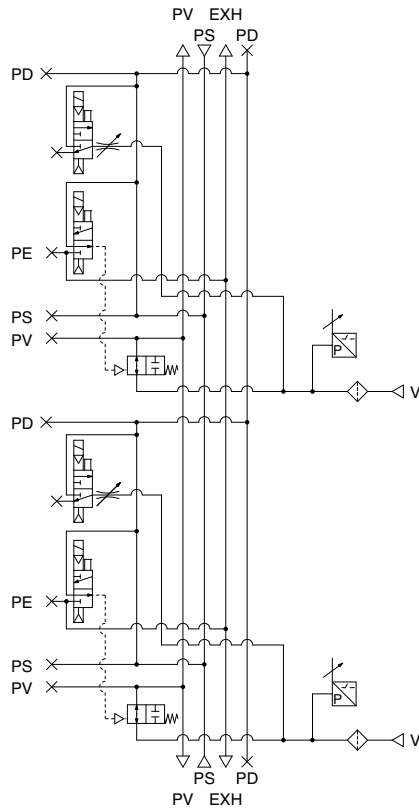

ZA

ZX

ZR

ZM

ZMA

ZQ

ZH

ZU

ZL

ZY □

ZF □

ZP □

SP

ZCUK

AMJ

AMV

AEP

HEP

Related
Equipment

Ejector System/Unit Construction (Refer to below for unit replacement.)

Single unit

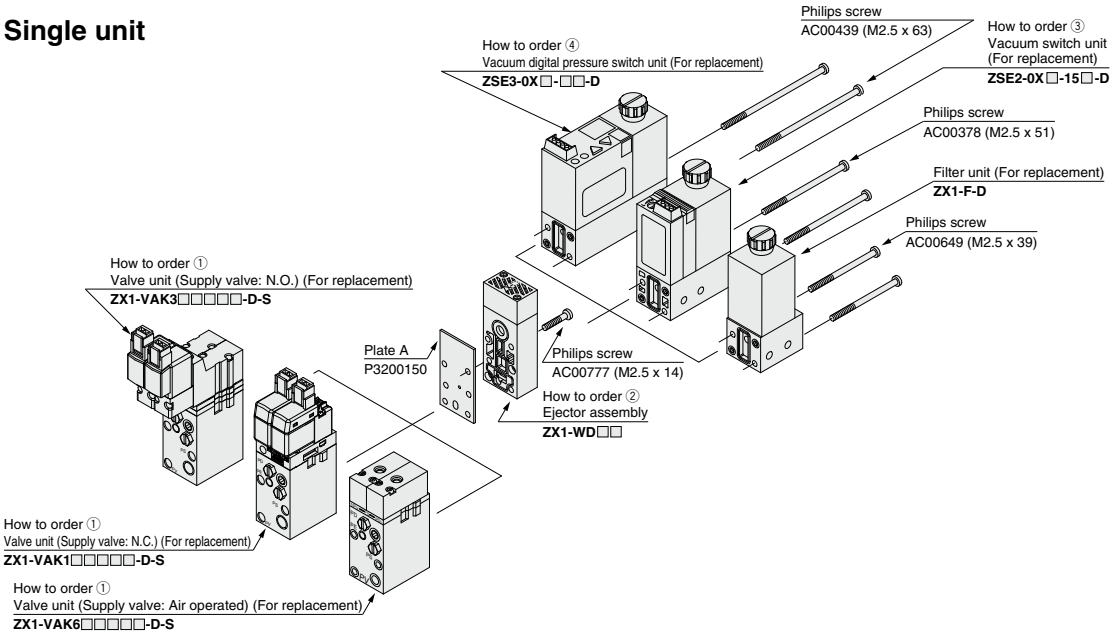

How to Order Unit for Replacement

① Valve unit

ZX1-V A K1 5 L Z B □ - L - D - S - □

For ejector system

Combination of supply valve and release valve (Refer to page 867 for details.)

Solenoid valve rated voltage

		CE-compliant
1*	100 VAC 50/60 Hz	—
3*	110 VAC 50/60 Hz	—
5	24 VDC	●
6	12 VDC	●
V	6 VDC	●
S	5 VDC	●
R	3 VDC	●

* Applicable to plug connector only. When replacing a product that uses a connector assembly with rectifier, replace the connector assembly as well. (Table (2) on page 867)

Unit for replacement	Release flow rate adjusting needle
Nil	Without lock nut
L	With lock nut

Unit for replacement	PV port size
Nil	M5 x 0.8
Y	M6 x 1 (Semi-standard)

Unit for replacement	Manual operation
Nil	Non-locking push type
B	Locking slotted type

Unit for replacement	Light/Surge voltage suppressor
Nil	None
Z	With light/surge voltage suppressor

Unit for replacement	Electrical entry
L	L plug connector

③ Vacuum switch unit

ZSE2-0X □ - 15 C - D

Unit for replacement	PV, V port size
Nil	M5 x 0.8
Y	M6 x 1 (Semi-standard)

Unit for replacement	Output specifications
15	NPN open collector
55	PNP open collector

Unit for replacement	Piping specifications
Nil	Grommet (0.6 m)
L	Grommet (3 m)
C	Connector (0.6 m)
CL	Connector (3 m)
CN	Without connector

④ Vacuum digital pressure switch unit

ZSE3-0X □ - 21 C - D

Unit for replacement	PV, V port size
Nil	M5 x 0.8
Y	M6 x 1 (Semi-standard)

Unit for replacement	Output specifications
21	2 outputs/without analog output
22	2 outputs/with analog output
23	1 output (with trouble detection)/without analog output
24	1 output (with trouble detection)/with analog output

Note) Analog output is available only on grommet type.

Unit for replacement	Piping specifications
Nil	Grommet (0.6 m)
L	Grommet (3 m)
C	Connector (0.6 m)
CL	Connector (3 m)
CN	Without connector

② Ejector assembly

ZX1-W D 05 1

Unit for replacement

Unit for replacement	Nozzle diameter
05	0.5 mm
07	0.7 mm
10	1.0 mm

Ejector exhaust

Unit for replacement	Ejector exhaust
1	Built-in silencer
2	Port exhaust Rc 1/8
2T	Port exhaust 1/8-NPTF

D: Unit for replacement

Ex.) If a filter unit is replaced for a vacuum switch on ZX1071-K15LZ-F, indicate as ZSE2-0X-15C-D. In this case, mounting screws AC00378 (M2.5 x 51) (2 pcs.) are required.

If the unit is used on its own, not combined with others, "D" is not required. (Valve unit, ejector assembly and switch unit)

Ex.) ZSE2-0X-15C, ZX1-VAK15LZ, ZX1-W051

Manifold

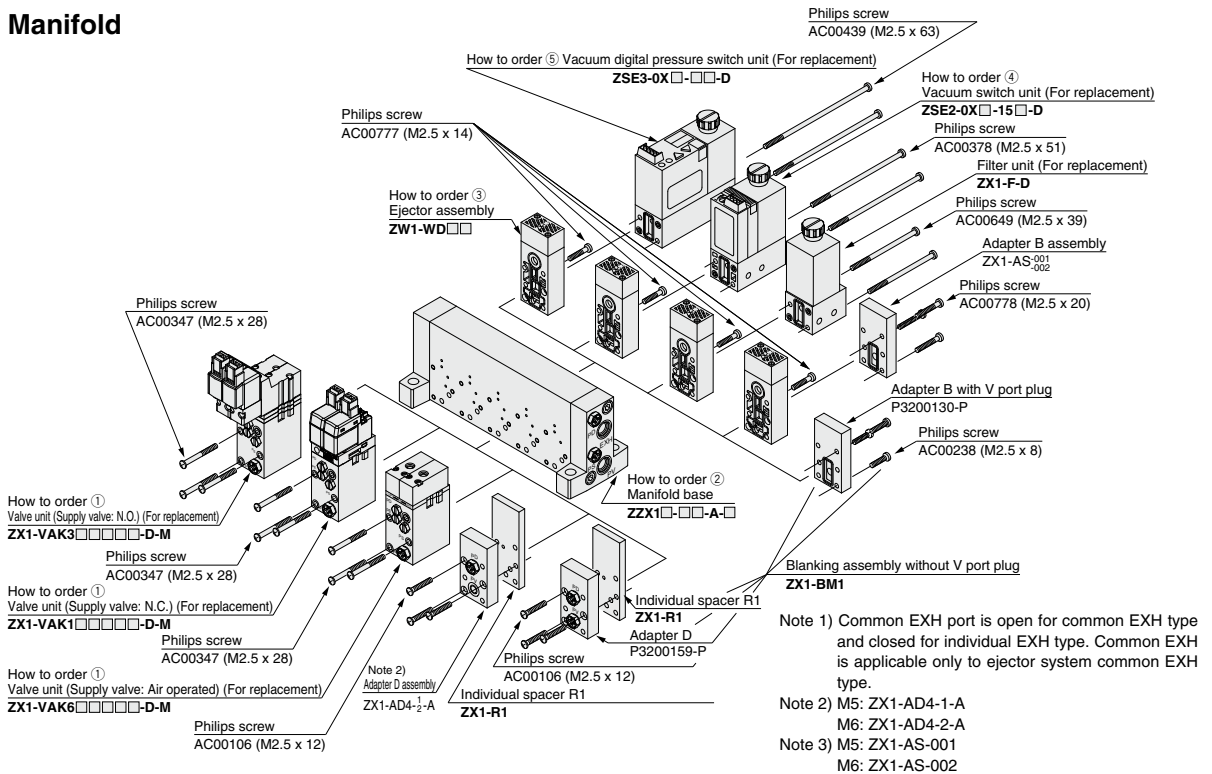

How to Order Unit for Replacement

① Valve unit * Refer to page 872 for details.

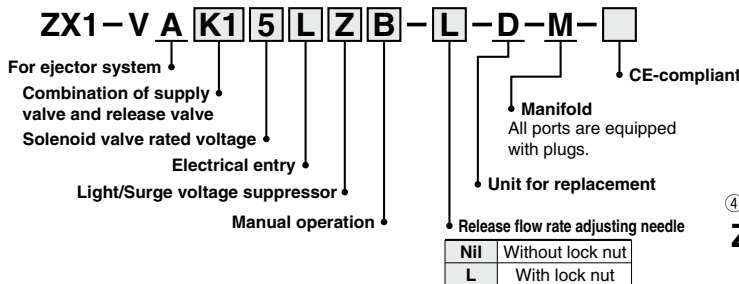

② Manifold base

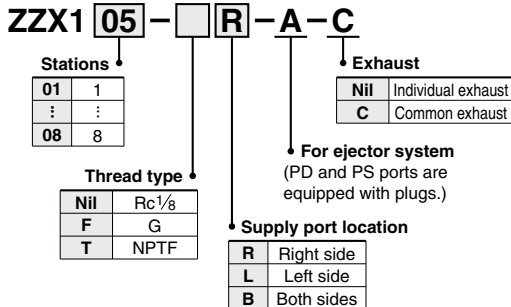

③ Ejector assembly

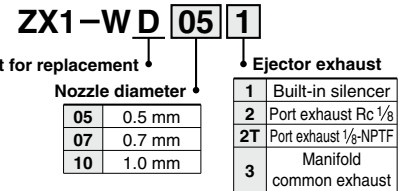

④ Vacuum switch unit

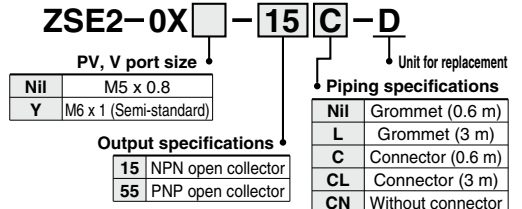

⑤ Vacuum digital pressure switch unit

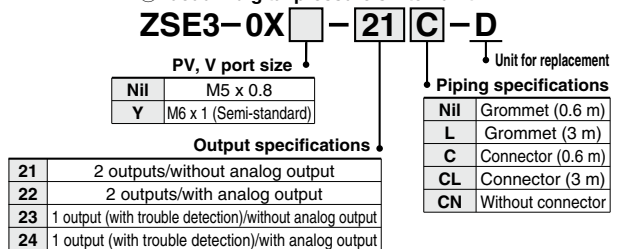

Note) Analog output is available only on grommet type.

- ZA
- ZX**
- ZR
- ZM
- ZMA
- ZQ
- ZH
- ZU
- ZL
- ZY□
- ZF□
- ZP□
- SP
- ZCUK
- AMJ
- AMV
- AEP
- HEP

Related Equipment

Vacuum Pump System/Unit Construction (Refer to below for unit replacement.)

Single unit

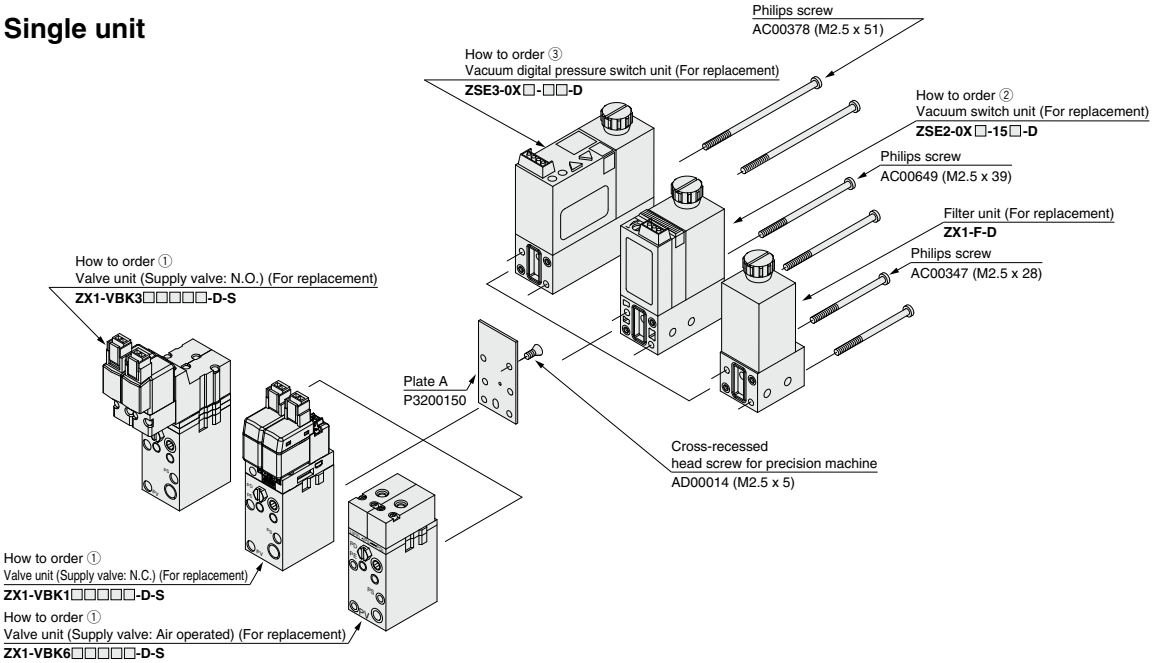

How to Order Unit for Replacement

① Valve unit

ZX1-VBK15LZB-L-D-S-

For vacuum pump system

Combination of supply valve and release valve (Refer to page 903 for details.)

Solenoid valve rated voltage

	CE-compliant
1*	100 VAC 50/60 Hz —
3*	110 VAC 50/60 Hz —
5	24 VDC ●
6	12 VDC ●
V	6 VDC ●
S	5 VDC ●
R	3 VDC ●

* Applicable to plug connector only. When replacing a product that uses a connector assembly with rectifier, replace the connector assembly as well. (Table (2) on page 903)

ZSE2-0X-15C-D

PV, V port size

Nil	M5 x 0.8
Y	M6 x 1 (Semi-standard)

Unit for replacement

Single unit (PD port is equipped with plug.)

Release flow rate adjusting needle

Nil	Without lock nut
L	With lock nut

PV port size

Nil	M5 x 0.8
Y	M6 x 1 (Semi-standard)

Manual operation

Nil	Non-locking push type
B	Locking slotted type

Light/Surge voltage suppressor

Nil	None
Z	With light/surge voltage suppressor

Electrical entry

L	L plug connector
---	------------------

② Vacuum switch unit

ZSE3-0X-21C-D

PV, V port size

Nil	M5 x 0.8
Y	M6 x 1 (Semi-standard)

Unit for replacement

Piping specifications

Nil	Grommet (0.6 m)
L	Grommet (3 m)
C	Connector (0.6 m)
CL	Connector (3 m)
CN	Without connector

Output specifications

15	NPN open collector
55	PNP open collector

③ Vacuum digital pressure switch unit

ZSE2-0X-15C-D

PV, V port size

Nil	M5 x 0.8
Y	M6 x 1 (Semi-standard)

Unit for replacement

Piping specifications

Nil	Grommet (0.6 m)
L	Grommet (3 m)
C	Connector (0.6 m)
CL	Connector (3 m)
CN	Without connector

Output specifications

21	2 outputs/without analog output
22	2 outputs/with analog output
23	1 output (with trouble detection)/without analog output
24	1 output (with trouble detection)/with analog output

Note) Analog output is available only on grommet type.

D: Unit for replacement

Ex.) If a filter unit is replaced for a vacuum switch on ZX100-K15LZ-F, indicate as ZSE2-0X-15C-D. In this case, mounting screws AC00796 (M2.5 x 39) (2 pcs.) are required.

If the unit is used on its own, not combined with others, "D" is not required.

Ex.) ZSE2-0X-15C, ZX1-VBK15LZ

Manifold

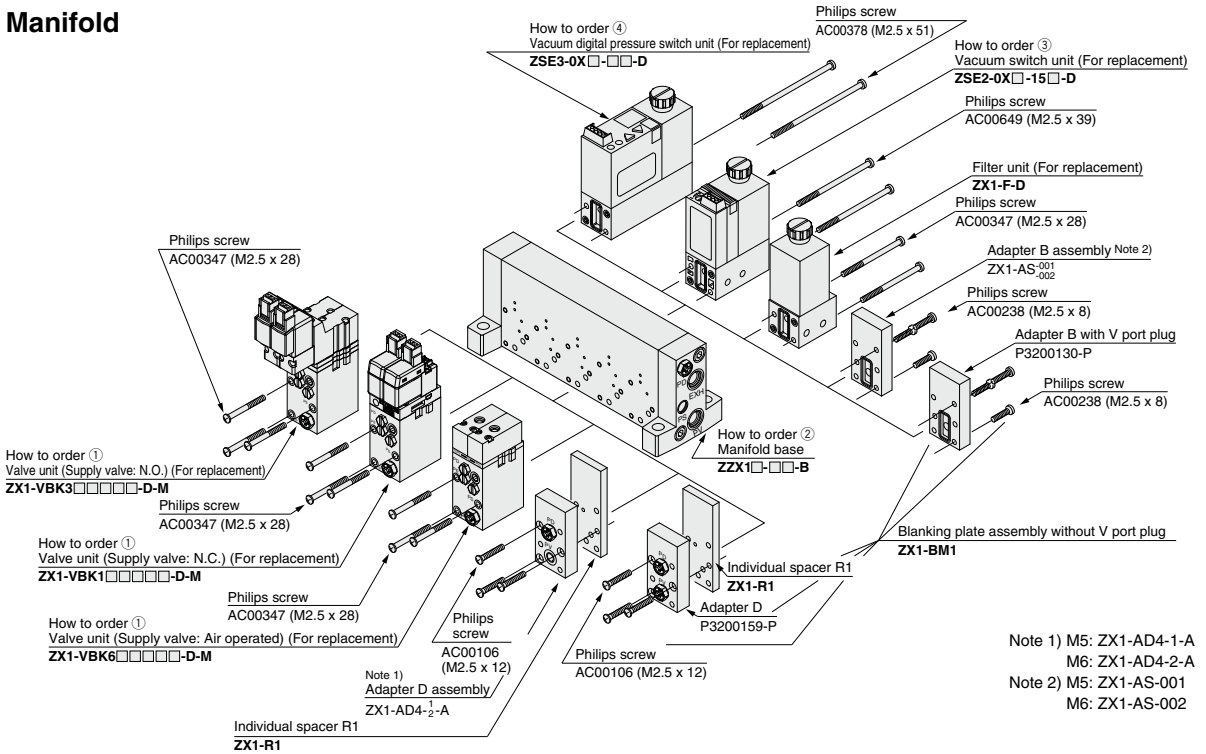

How to Order Unit for Replacement

① Valve unit * Refer to page 906 for details.

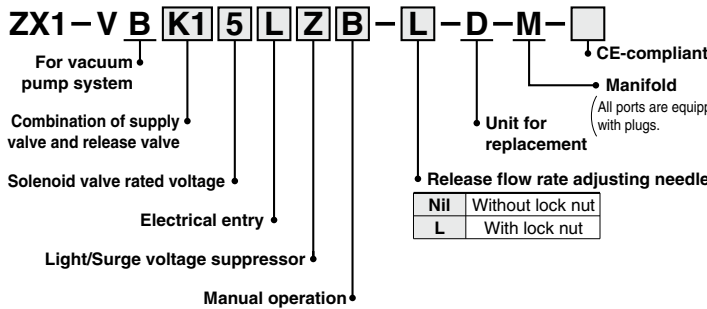

③ Vacuum switch unit

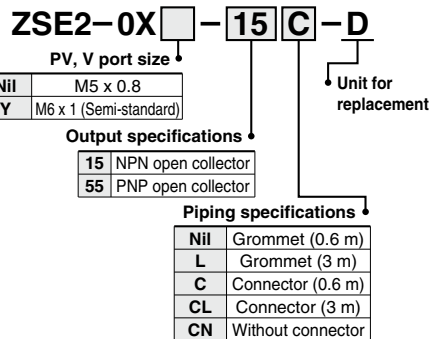

② Manifold base * Refer to page 916 for details.

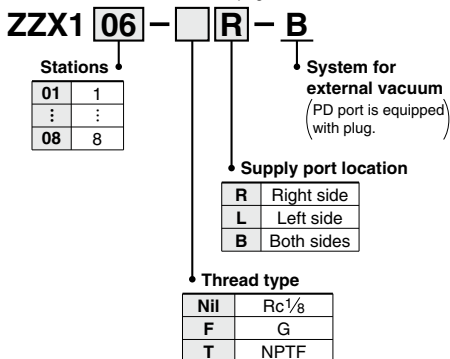

④ Vacuum digital pressure switch unit

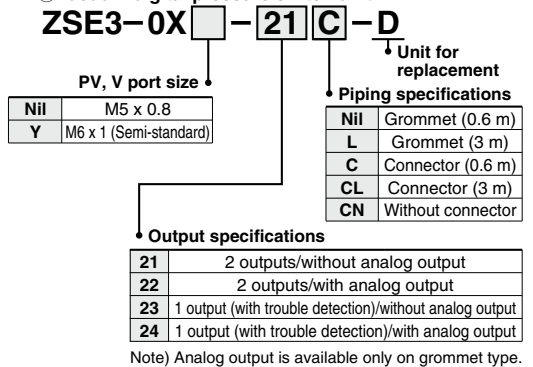

ZA
ZX
 ZR
 ZM
 ZMA
 ZQ
 ZH
 ZU
 ZL
 ZY□
 ZF□
 ZP□
 SP
 ZCUK
 AMJ
 AMV
 AEP
 HEP
 Related Equipment

Vacuum Pump System/Manifold Assembly from Individual Unit

Manifold Assembly from individual unit

1. Remove Philips screws.
2. Remove cross-recessed head machine screw for precision machinery.
3. Mount plugs to valve unit.
4. Mount valve unit with Philips screws AC00347 (M2.5 x 28) 3 pcs.
5. Mount vacuum switch to manifold with Philips screws 2 pcs.
Follow tightening screw torque on Table (1).

Note 1)

Even though screw type in use differs depending on the combination (Table (2)), screws for an individual unit and a manifold are common.

Table (2)

Combination	Part no.
Vacuum switch ZSE3	AC00378 (M2.5 x 51)
Vacuum switch ZSE2	AC00649 (M2.5 x 39)
Filter unit ZX1-F	AC00347 (M2.5 x 28)

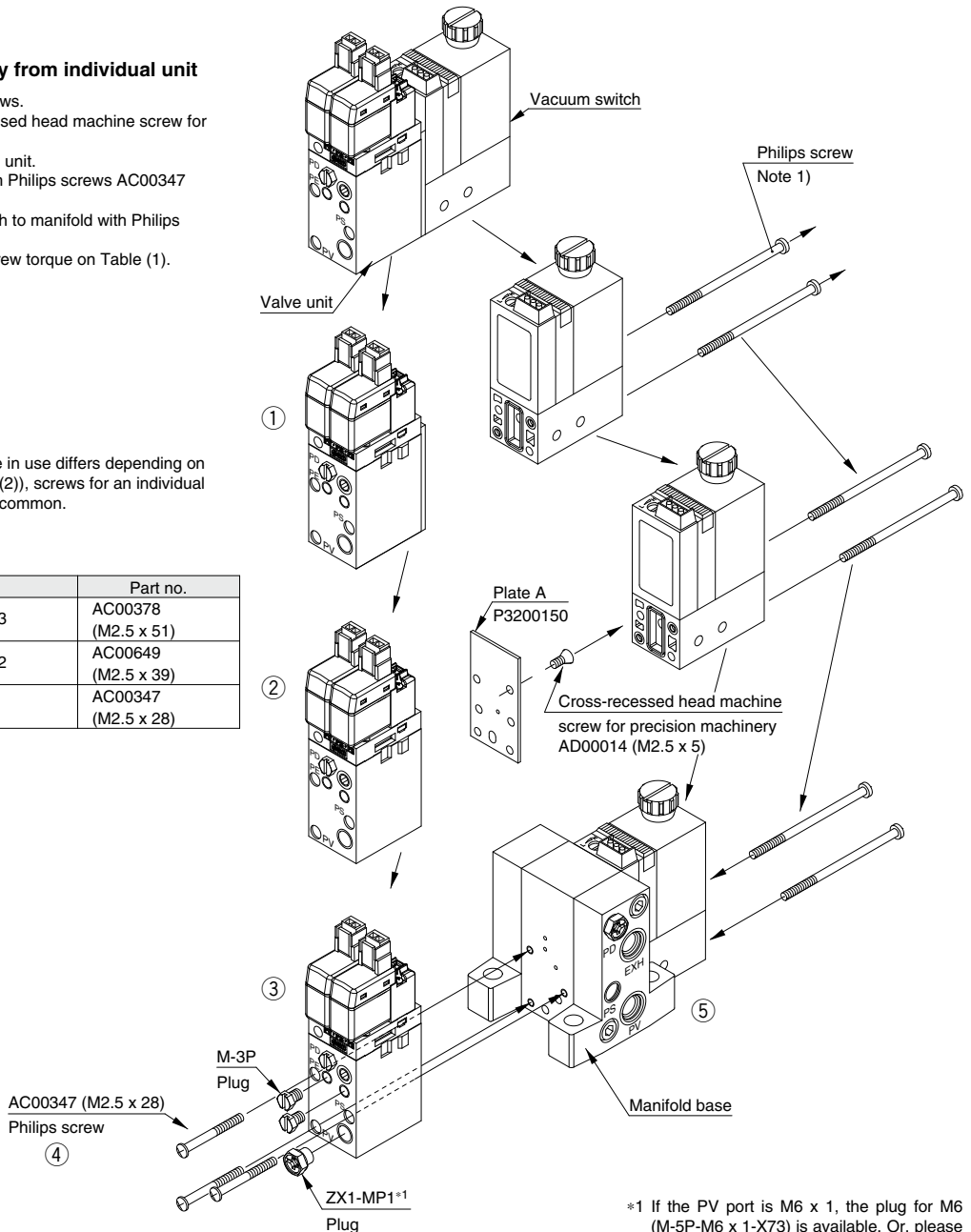

*1 If the PV port is M6 x 1, the plug for M6 (M-5P-M6 x 1-X73) is available. Or, please consider replacing the valve unit with a valve unit for manifold (① on page 927).

Table (1)

Part no.	Description	Quantity	Recommended tightening screw torque	In the case of manifold	Single unit
Note 1)	Philips screw	2	0.28 ± 0.1 (N·m)	Necessary	Necessary
P3200150	Plate A	1		Not necessary	Necessary
AD00014 (M2.5 x 5)	Cross-recessed head machine screw for precision machinery	1	0.28 ± 0.1 (N·m)	Not necessary	Necessary
M-3P	Plug	2	0.46 ± 0.05 (N·m)	Necessary	Not necessary
ZX1-MP1*1	Plug	1	1.6 ± 0.15 (N·m)	Necessary	Not necessary
AC00347* (M2.5 x 28)	Philips screw	3	0.28 ± 0.1 (N·m)	Necessary	Not necessary

* Use AC00018 (M2.5 x 32) when individual spacers are used.

Ejector System/Manifold Assembly from Individual Unit

Manifold Assembly from individual unit

1. Remove Philips screws.
2. Remove Philips screws, and then remove ejector assembly from valve unit.
3. Mount plugs to valve unit.
4. Mount valve unit with Philips screws AC00347 (M2.5 x 28) 3 pcs.
5. Mount ejector assembly to manifold with Philips screw AC00777 (M2.5 x 14) 1 pc.
6. Mount vacuum switch to manifold with Philips screws 2 pcs.

Note 1)

Even though screw type in use differs depending on the combination (Table (2)), screws for an individual unit and a manifold are common.
Follow tightening screw torque on Table (1).

Table (2)

Combination	Part no.
Vacuum switch ZSE3	AC00439 (M2.5 x 63)
Vacuum switch ZSE2	AC00378 (M2.5 x 51)
Filter unit ZX1-F	AC00649 (M2.5 x 39)

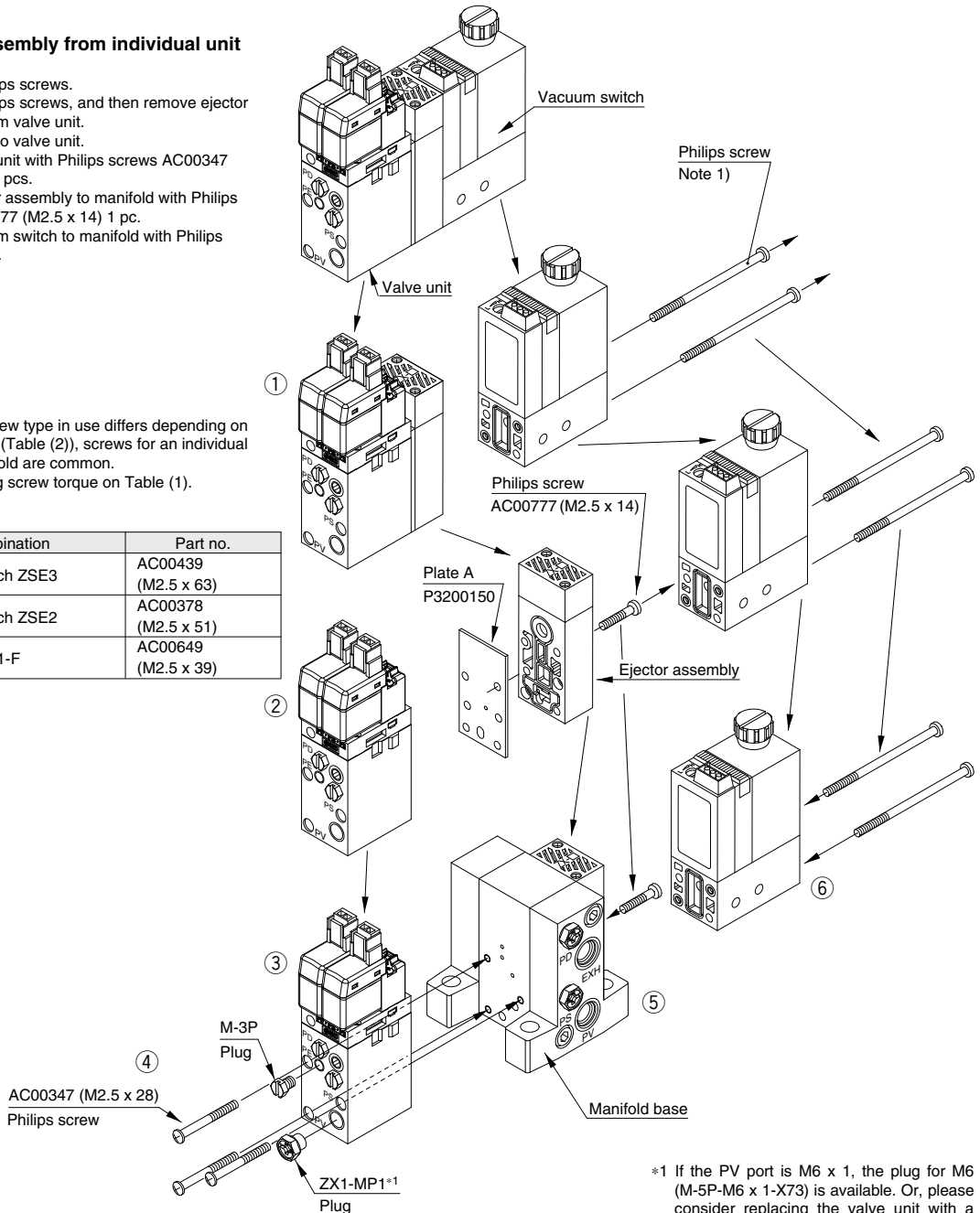

*1 If the PV port is M6 x 1, the plug for M6 (M-5P-M6 x 1-X73) is available. Or, please consider replacing the valve unit with a valve unit for manifold (① on page 925).

Table (1)

Part no.	Description	Quantity	Recommended tightening screw torque	In the case of manifold	Single unit
Note 1)	Philips screw	2	0.28 ± 0.1 (N·m)	Necessary	Necessary
P3200150	Plate A	1		Not necessary	Necessary
AC00777 (M2.5 x 14)	Philips screw	1	0.28 ± 0.1 (N·m)	Necessary	Necessary
M-3P	Plug	1	0.46 ± 0.05 (N·m)	Necessary	Not necessary
ZX1-MP1 *1	Plug	1	1.6 ± 0.15 (N·m)	Necessary	Not necessary
AC00347 * (M2.5 x 28)	Philips screw	3	0.28 ± 0.1 (N·m)	Necessary	Not necessary

* Use AC00018 (M2.5 x 32) when individual spacers are used.



Please consult with SMC for detailed size, specifications and delivery.

1 Valve Unit/Other Combinations of Supply Valve and Release Valve (Ejector unit)

Ejector Unit

If those other than the standard combination of supply valves and release valves (Refer to page 867.) are required, select from the following combinations. (Refer to page 866 for "How to Order".)

Combination Symbol: K2

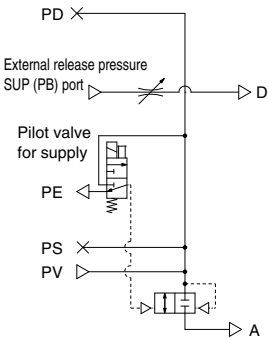

Application: The supply pressure is controlled by electric signals and a vacuum release is effected by external air.

How to Operate

Valve Condition	Supply valve	Release valve
	Solenoid valve	External 2 port valve
1. Work adsorption	ON	OFF
2. Vacuum release	OFF	ON
3. Operation stop	OFF	OFF

Combination Symbol: K7

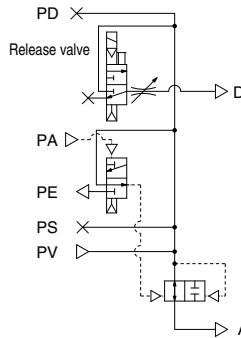

Application: The supply pressure is controlled by external air signals and a vacuum release is effected by the solenoid valve. Because the supply valve is N.O., the pressure that is supplied to the ejector is not interrupted during a power outage; as a result, the state of suction can be maintained. This combination is used for preventing the workpieces from dropping during power outages.

How to Operate

Valve Condition	Supply valve	Release valve
	Air operated valve	Solenoid valve
1. Work adsorption	OFF	OFF
2. Vacuum release	ON	ON
3. Operation stop	ON	OFF

Combination Symbol: K4

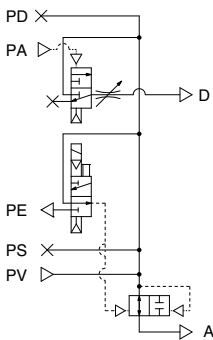

Application: The supply pressure is restricted by electric signals and a vacuum release is effected by air signals. Because the supply valve is N.O., the pressure that is supplied to the ejector is not interrupted during a power outage; as a result, the state of suction can be maintained. This combination is used for preventing the workpieces from dropping during power outages.

How to Operate

Valve Condition	Supply valve	Release valve
	Solenoid valve	Air operated valve
1. Work adsorption	OFF	OFF
2. Vacuum release	ON	ON
3. Operation stop	ON	OFF

Combination Symbol: J1

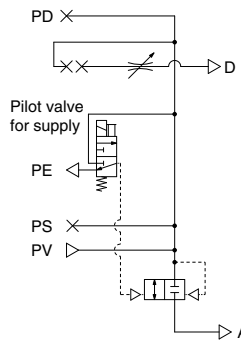

Application: This combination is used for effecting control in accordance with electric signals. A vacuum release is effected by the intrusion of air between the silencer, pad, and the workpiece. This combination is used when there is no need to accelerate the vacuum release speed.

How to Operate

Valve Condition	Supply valve	Release valve
	Solenoid valve	—
1. Work adsorption	ON	—
2. Vacuum release	OFF	—
3. Operation stop	OFF	—

Combination Symbol: K5

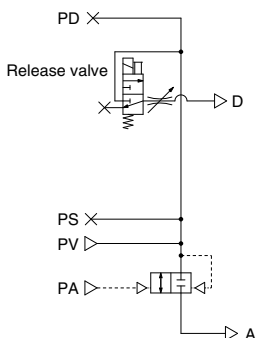

Application: The supply pressure is controlled by external air signals and a vacuum release is effected by the solenoid valve.

How to Operate

Valve Condition	Supply valve	Release valve
	External 3 port valve	Solenoid valve
1. Work adsorption	ON	OFF
2. Vacuum release	OFF	ON
3. Operation stop	OFF	OFF

Combination Symbol: J2

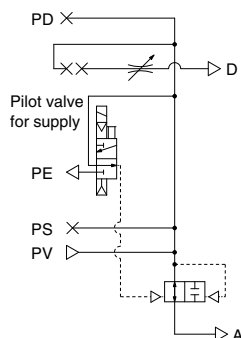

Application: It is used for controlling the supply pressure through electric signals. Because the supply valve is N.O., the pressure that is supplied to the ejector is not interrupted during a power outage; as a result, the state of suction can be maintained. This is used for preventing the workpieces from dropping during power outages. A vacuum release is effected by the intrusion of air between the silencer, pad, and the workpiece. This combination is used when there is no need to accelerate the vacuum release speed.

How to Operate

Valve Condition	Supply valve	Release valve
	Solenoid valve	—
1. Work adsorption	OFF	—
2. Vacuum release	ON	—
3. Operation stop	ON	—

Combination Symbol: J3

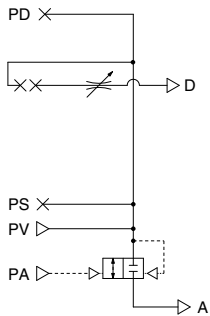

Application: The supply pressure is controlled by external air signals. A vacuum release is effected by the intrusion of air between the silencer, pad, and the workpiece. This is used when there is no need to accelerate the vacuum release speed.

How to Operate

Valve	Supply valve	Release valve
Condition	External 3 port valve	—
1. Work adsorption	ON	—
2. Vacuum release	OFF	—
3. Operation stop	OFF	—

Combination Symbol: J4

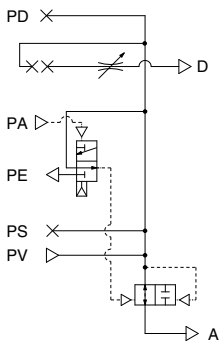

Application: The supply pressure is controlled by external air signals. Because the supply valve is N.O., the pressure that is supplied to the ejector is not interrupted during a power outage; as a result, the state of suction can be maintained. This is used for preventing the workpieces from dropping during power outages. A vacuum release is effected by the intrusion of air between the silencer, pad, and the workpiece. This type is used when there is no need to accelerate the vacuum release speed.

How to Operate

Valve	Supply valve	Release valve
Condition	Air operated valve	—
1. Work adsorption	OFF	—
2. Vacuum release	ON	—
3. Operation stop	OFF	—

Combination Symbol: D1

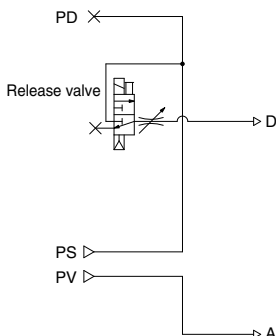

Application: The supply pressure is controlled by the external valve and a vacuum release is effected by the solenoid valve.

How to Operate

Valve	Supply valve	Release valve
Condition	External valve	Solenoid valve
1. Work adsorption	ON	OFF
2. Vacuum release	OFF	ON
3. Operation stop	OFF	OFF

Combination Symbol: D2

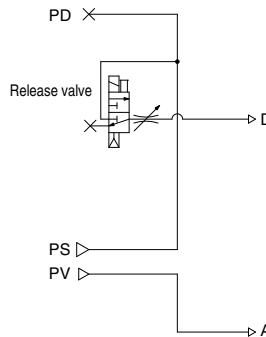

Application: The supply pressure is controlled by the external valve and a vacuum release is effected by the solenoid valve.

How to Operate

Valve	Supply valve	Release valve
Condition	External valve	Solenoid valve
1. Work adsorption	ON	OFF
2. Vacuum release	OFF	ON
3. Operation stop	OFF	OFF

Combination Symbol: D3

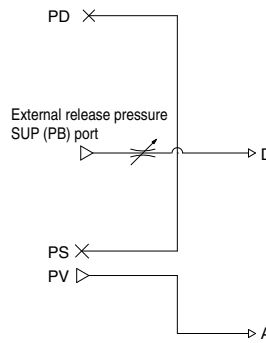

Application: The supply pressure is controlled by the external valve and a vacuum release is effected by the external 2 port valve (vacuum valve).

How to Operate

Valve	Supply valve	Release valve
Condition	External valve	Solenoid valve
1. Work adsorption	ON	OFF
2. Vacuum release	OFF	ON
3. Operation stop	OFF	OFF

Combination Symbol: D4

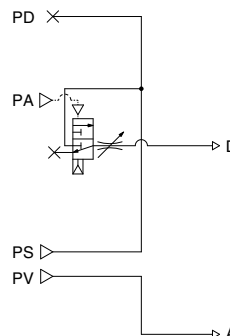

Application: The supply pressure is controlled by the external valve and a vacuum release is effected by external air signals.

How to Operate

Valve	Supply valve	Release valve
Condition	External valve	Air operated valve
1. Work adsorption	ON	OFF
2. Vacuum release	OFF	ON
3. Operation stop	OFF	OFF

ZA

ZX

ZR

ZM

ZMA

ZQ

ZH

ZU

ZL

ZY □

ZF □

ZP □

SP

ZCUK

AMJ

AMV

AEP

HEP

Related Equipment



Please consult with SMC for detailed size, specifications and delivery.

2 Valve Unit/Other Combinations of Supply Valve and Release Valve (Vacuum pump system)

Vacuum Pump System

If those other than the standard combination of supply valves (Refer to page 903.) and release valves are required, select from the following combinations. (Refer to page 902 for "How to Order".)

Combination Symbol: K2

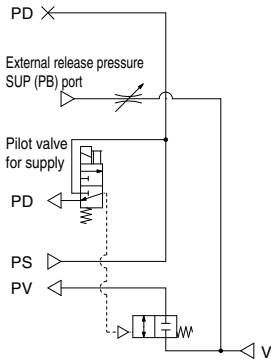

Application: The supply pressure is controlled by electric signals and a vacuum release is effected by external air.

How to Operate

Condition	Valve	Supply valve	Release valve
		Solenoid valve	External 2 port valve
1. Work adsorption		ON	OFF
2. Vacuum release		OFF	ON
3. Operation stop		OFF	OFF

Combination Symbol: K7

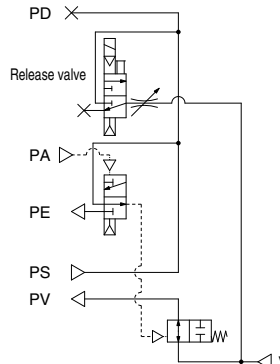

Application: The supply pressure is controlled by external air signals and a vacuum release is effected by the solenoid valve. Because the supply valve is the N.O., the pressure that is supplied to the ejector is not interrupted during a power outage; as a result, the state of suction can be maintained. This combination is used for preventing the workpieces from dropping during power outages.

How to Operate

Condition	Valve	Supply valve	Release valve
		Air operated valve	Solenoid valve
1. Work adsorption		OFF	OFF
2. Vacuum release		ON	ON
3. Operation stop		ON	OFF

Combination Symbol: K4

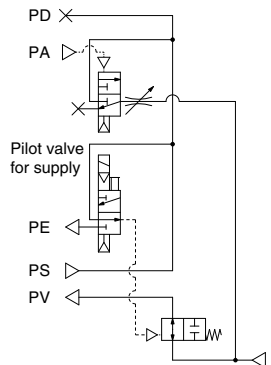

Application: The supply pressure is controlled by electric signals and a vacuum release is effected by air signals. Because the supply valve is N.O., the pressure that is supplied to the ejector is not interrupted during a power outage; as a result, the state of suction can be maintained. This combination is used for preventing the workpieces from dropping during power outages.

How to Operate

Condition	Valve	Supply valve	Release valve
		Solenoid valve	Solenoid valve
1. Work adsorption		OFF	OFF
2. Vacuum release		ON	ON
3. Operation stop		ON	ON

Combination Symbol: J1

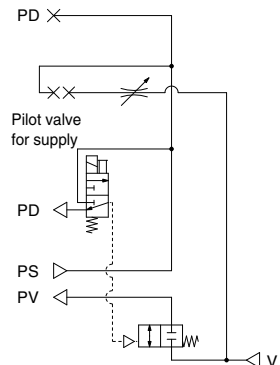

Application: This combination is used for controlling the pressure by electric signals. Normally, the workpiece is released due to the air leakage that occurs between the pad and the workpiece. However, if there is no air leakage, the workpiece will not become detached because the vacuum state is maintained even when the supply valve is turned OFF. To effect releasing, an external 2 port valve (vacuum valve) must be provided.

How to Operate

Condition	Valve	Supply valve	Release valve
		Solenoid valve	————
1. Work adsorption		ON	————
2. Vacuum release		OFF	————
3. Operation stop		OFF	————

Combination Symbol: K5

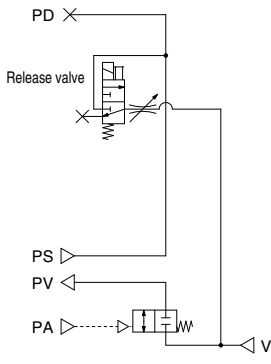

Application: The supply pressure is controlled by external air signals and a vacuum release is effected by the solenoid valve.

How to Operate

Condition	Valve	Supply valve	Release valve
		External 3 port valve	Solenoid valve
1. Work adsorption		ON	OFF
2. Vacuum release		OFF	ON
3. Operation stop		OFF	OFF

Combination Symbol: J2

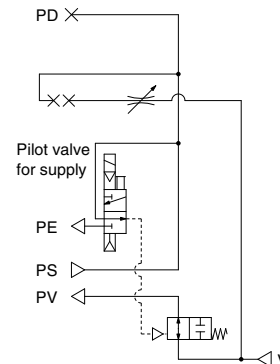

Application: Used for controlling with electric signals. Because the supply N.O., the pressure is not interrupted during a power outage. This prevents the workpieces from dropping. Normally, the workpiece is released due to leakage. However, if no air leakage, the workpiece will not detach because the vacuum state is maintained even when the supply valve is turned ON. To release, an external 2 port valve (vacuum valve) must be used.

How to Operate

Condition	Valve	Supply valve	Release valve
		Solenoid valve	————
1. Work adsorption		OFF	————
2. Vacuum release		ON	————
3. Operation stop		ON	————

Combination Symbol: J3

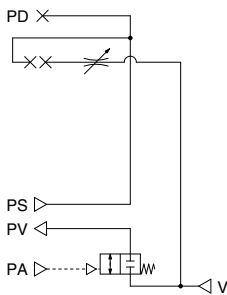

Application: The supply pressure is controlled by external air signals. Normally, the workpiece is released due to the air leakage that occurs between the pad and the workpiece. However, if there is no air leakage, the workpiece will not become detached because the vacuum state is maintained even when the supply valve is turned OFF. To effect releasing, an external 2 port valve (vacuum valve) must be provided.

How to Operate

Valve	Supply valve	Release valve
Condition	External 3 port valve	—
1. Work adsorption	ON	—
2. Vacuum release	OFF	—
3. Operation stop	OFF	—

Combination Symbol: J4

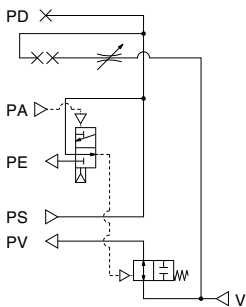

Application: Supply is controlled by external air signals. Because the valve is N.O., the pressure is not interrupted during a power outage. This prevents the workpieces from dropping. Normally, the workpiece is released due to leakage. However, if no leakage, the workpiece will not detach because the vacuum state is maintained even when the valve is turned ON. To release, an external 2 port valve (vacuum valve) must be provided.

How to Operate

Valve	Supply valve	Release valve
Condition	Air operated valve	—
1. Work adsorption	OFF	—
2. Vacuum release	ON	—
3. Operation stop	ON	—

Combination Symbol: D1

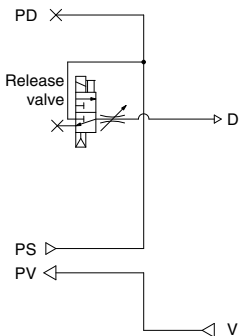

Application: The supply pressure is controlled by an external 2 port valve (vacuum valve) and a vacuum release is effected by the solenoid.

How to Operate

Valve	Supply valve	Release valve
Condition	External 2 port valve	Solenoid valve
1. Work adsorption	ON	OFF
2. Vacuum release	OFF	ON
3. Operation stop	OFF	OFF

Combination Symbol: D2

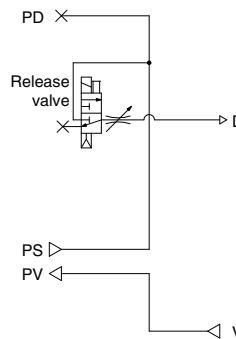

Application: The supply pressure is controlled by an external 2 port valve (vacuum valve) and a vacuum release is effected by the solenoid.

How to Operate

Valve	Supply valve	Release valve
Condition	External 2 port valve	Solenoid valve
1. Work adsorption	ON	OFF
2. Vacuum release	OFF	ON
3. Operation stop	OFF	OFF

Combination Symbol: D3

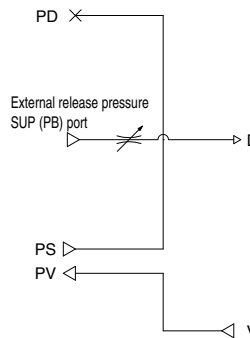

Application: The supply pressure is controlled by the external 2 port valve (vacuum valve) and releasing is also effected by the external 2 port valve.

How to Operate

Valve	Supply valve	Release valve
Condition	External 2 port valve	Solenoid valve
1. Work adsorption	ON	OFF
2. Vacuum release	OFF	ON
3. Operation stop	OFF	OFF

Combination Symbol: D4

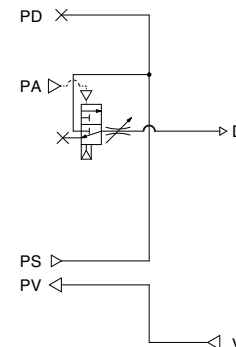

Application: The supply pressure is controlled by the external 2 port valve (vacuum valve) and vacuum release is effected by external air signals.

How to Operate

Valve	Supply valve	Release valve
Condition	External 2 port valve	Solenoid valve
1. Work adsorption	ON	OFF
2. Vacuum release	OFF	ON
3. Operation stop	OFF	OFF

ZA

ZX

ZR

ZM

ZMA

ZQ

ZH

ZU

ZL

ZY□

ZF□

ZP□

SP

ZCUK

AMJ

AMV

AEP

HEP

Related Equipment

3 High Noise Reduction Silencer Assembly

ZX1 Nozzle diameter Exhaust style — Valve Voltage Electrical entry X121 — CE-compliant

High noise reduction silencer assembly

Reduction in the exhaust noise from the ejector (Silencing effect 8 dB (A) Standard silencer assembly comparison)

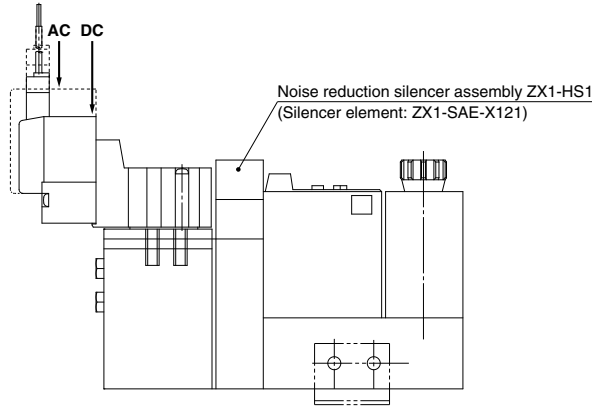

Ordering example
ZX1101-K35LZ-D23C-X121

Noise reduction silencer assembly ZX1-HS1
(Silencer element: ZX1-SAE-X121)

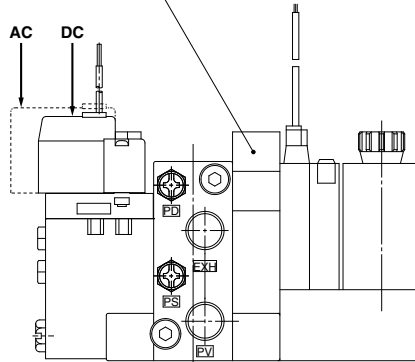

Ordering example
ZZX102-R 1 pc.
* ZX1101-K15LZ-EC-X121 2 pcs.